

JANUARY
1937

VOLUME CONTROL SERVICING

RADIO WORLD

REG. U.S. PAT. OFF.

LOW-COST OSCILLOSCOPE

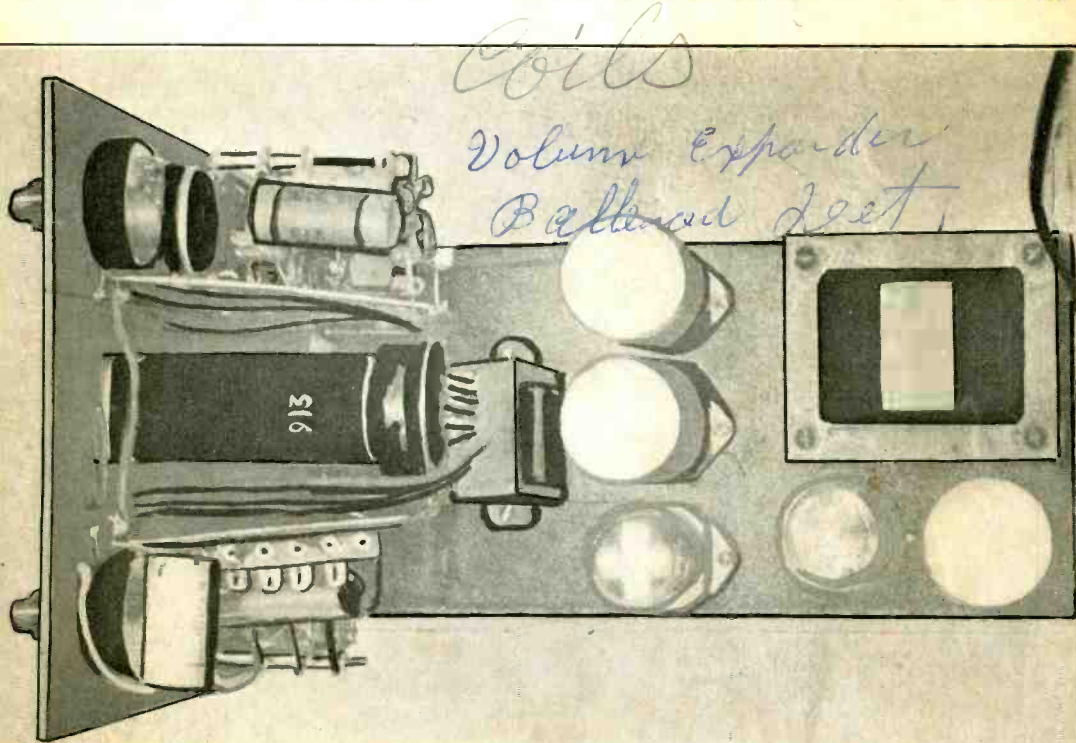

Due to the relatively low voltages required by the new, inexpensive 913 cathode-ray tube, an oscilloscope may be built at small cost. See detailed article, beginning on page 8.

25c
Per Copy

**FIRST
IN PEACE
FIRST
IN WAR**

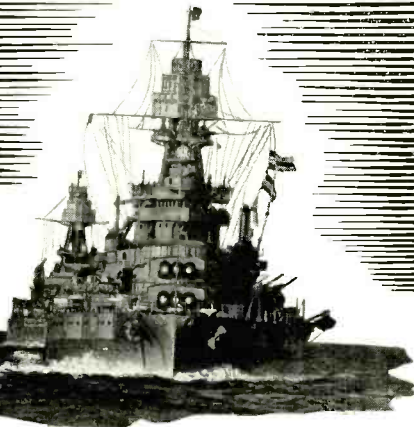

ALWAYS FIRST CHOICE OF SERVICEMEN

THE split second maneuvers of a great battle fleet are dependent upon transmitters which employ C-D Condensers. In great Broadcasting stations—as well as in “Ham” rigs—you’ll also find C-D Xmitting Condensers!

We are proud of the acceptance of C-D condensers in war time and peace time communication, but we are just as proud of the legions of Servicemen who are loyal C-D “boosters.” To their insistence on Quality Replacement Condensers, we attribute the enormous production schedules of the great C-D factory—the largest in the world devoted exclusively to the manufacture of condensers.

For every radio requirement there's a C-D condenser. Be wise—standardize on C-D's! Write for Catalog No. 128 and supplements 132A, 133A and 134A.

MICA * DYKANOL * PAPER
WET and DRY ELECTROLYTIC
CORNELL-DUBILIER CORP.
1024 Hamilton Boulevard
So. Plainfield, N. J.

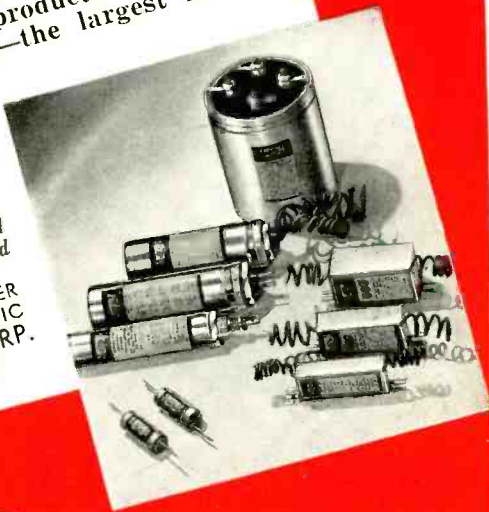

CORNELL DUBILIER



I'LL SEND MY FIRST LESSON FREE

It Shows How I Train You at Home in Your Spare Time for a GOOD JOB IN RADIO



**J. E. Smith, President
National Radio Institute**

The man who has directed the home study training of more men for the Radio Industry than any other man in America.



**Service
Manager
For Four
Stores**

"I was working in a garage when I enrolled with N. R. I. In a few months I made enough to pay for the course three or four times. I am now Radio service manager for the M— Furniture Co., for their four stores."—**JAMES E. RYAN**, 1535 Stade St., Fall River, Mass.

**\$10 Week
in
Spare Time**



"My work has consisted of Radio set servicing, with some Public Address Systems work—all in my spare time. My earnings in Radio amount to about \$10 a week."—**WILLIAM MEYER**, 705 Ridge Road, Hobart, Ind.



**Earnings
Tripled
By N.R.I.
Training**

"I have been doing nicely, thanks to N. R. I. Training. My present earnings are about three times what they were before I took the Course. I consider N. R. I. Training the finest in the world."—**BERNARD COSTA**, 201 Kent St., Brooklyn, N. Y.

Clip the coupon and mail it. I will prove to you that I can train you at home in your spare time to be a RADIO EXPERT. I will send you my first lesson FREE. Examine it, read it, see how clear and easy it is to understand—how practical I make learning Radio at home. Then you will know why men without Radio or electrical experience have become Radio Experts and are earning more money than ever as a result of my Training.

Many Radio Experts Make \$30, \$50, \$75 a Week

Radio broadcasting stations employ engineers, operators, station managers and pay up to \$5,000 a year. Spare time Radio set servicing pays as much as \$200 to \$500 a year—full time jobs with Radio jobbers, manufacturers and dealers as much as \$30, \$50, \$75 a week. Many Radio Experts operate their own full time or part time Radio sales and service businesses. Radio manufacturers and jobbers employ testers, inspectors, foremen, engineers, servicemen, paying up to \$6,000 a year. Radio operators on ships get good pay and see the world besides. Automobile, police, aviation, commercial Radio, and loud speaker systems are newer fields offering good opportunities now and for the future. Television promises to open many good jobs soon. Men I have trained are holding good jobs in these branches of Radio. Read their statements. Mail the coupon.

There's a Real Future in Radio for Well Trained Men

Radio already gives jobs to more than 300,000 people. In 1935 over \$300,000,000 worth of sets, tubes and parts were sold—an increase of 20% over 1934! Over 1,100,000 auto Radios were sold in 1935, 25% more than in 1934! 22,000,000 homes are today equipped with Radios, and every year millions of these sets go out of date and are replaced with newer models. Millions more need servicing, new tubes, repairs, etc. Broadcasting stations pay their employees (exclusive of artists) more than \$23,000,000 a year! And Radio is a new industry, still growing fast! A few hundred \$30, \$50, \$75-a-week jobs have grown to many thousands in less than 20 years.

Many Make \$5, \$10, \$15 a Week Extra in Spare Time While Learning

Practically every neighborhood needs a good spare time serviceman. The day you enroll I start sending you Extra Money Job Sheets. They show you how to do Radio repair jobs that you can cash in on quickly. Throughout your training I send you plans that made good spare time money—\$200 to \$500 a year—for hundreds of fellows. My Training is famous as "the Course that pays for itself."

I Give You Practical Experience

My Course is not all book training. I send you special Radio equipment and show you how to conduct experiments and build circuits which illustrate important principles used in modern Radio receivers, broadcast stations and loud speaker



installations. I show you how to build testing apparatus for use in spare time work from this equipment. Read about this 50-50 method of training—how it makes learning at home interesting, quick, fascinating, practical. Mail coupon.

Money Back Agreement Protects You
I am so sure that I can train you successfully that I agree in writing to refund every penny you pay me if you are not satisfied with my Lessons and Instruction Service when you finish. I'll send you a copy of this agreement with my Free Book.

Find Out What Radio Offers You

Mail coupon for sample lesson and 64-page book. Both are free to anyone over 16 years old. My book describes Radio's spare time and full time opportunities and those coming in Television; tells about my training in Radio and Television; shows you actual letters from men I have trained, telling what they are doing and earning. Find out what Radio offers YOU! MAIL THE COUPON in an envelope, or paste it on a penny post card—NOW!

**J. E. SMITH, President, Dept. 7AM4
National Radio Institute, Washington, D. C.**

**MAIL
COUPON
NOW!**



GOOD FOR BOTH 64 PAGE BOOK FREE SAMPLE LESSON FREE

**J. E. SMITH, President, Dept. 7AM4
National Radio Institute, Washington, D. C.**

Dear Mr. Smith: Without obligating me, send the sample lesson and your book which tells about the spare time and full time opportunities in Radio and explains your 50-50 method of training men at home in spare time to become Radio Experts. (Please write plainly.)

NAME..... AGE.....

ADDRESS.....

CITY..... STATE.....

14x1

**The Tested WAY
to BETTER PAY**

Announcing

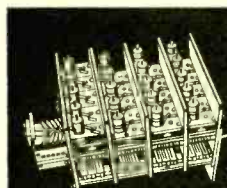

★ PRECISION TUNING UNIT

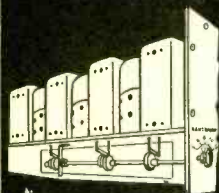

★ BAND WIDTH CONTROL

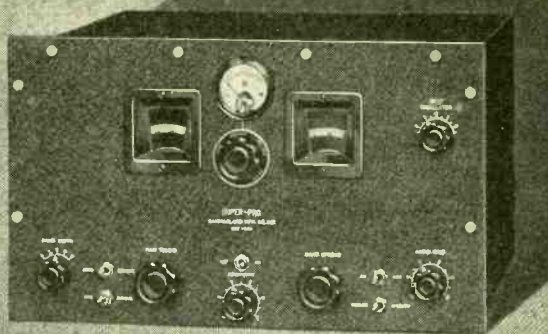

★ CALIBRATED BEAT OSCILLATOR

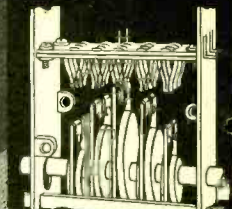

★ NOISELESS SWITCH

THE *New* "SUPER-PRO"

HAMMARLUND now introduces an outstanding receiver for .54 to 20.0 megacycles that provides a new high in efficiency—the new "Super-Pro," "100" series!

With this new "Super-Pro" you can now continuously vary the selectivity from 3 to 16 kc. by means of a directly calibrated "Band Width" control on the front panel. At last, no more guess work!

For C. W., the new "Super-Pro" also has a beat oscillator control directly calibrated from 0 to 2.5 kilocycles on either side of the zero beat. Audio gain and sensitivity gain controls are also graduated to facilitate accurate tuning.

A crystal model is also available. This model affords selectivity from a knife-like point desired for C. W. code to a wider degree of selectivity required for practical phone reception.

Another major feature is the band spread system with a 12 gang condenser which spreads each amateur band over practically the entire dial. High frequency

broadcast channels are similarly spread for extra easy tuning.

The exclusive "Super-Pro" cam-operated knife switch is noiseless, jar-proof and fool-proof. Within the precision tuning unit are 20 laboratory adjusted tuning coils on Isolantite bases, a four-gang main tuning condenser, and a 12 to 1 ratio direct reading dial, calibrated in megacycles and kilocycles, accurate to within 1/2%.

The sensitivity of this new receiver using 16 tubes, eight metal and eight glass, is so great that weak signal reception is limited only by the noise pick up of the antenna system.

Write for special "Super-Pro" bulletin, with further details and illustrations!

HAMMARLUND MANUFACTURING CO., Inc.
424-438 W. 33rd St., New York City RW-1-37

- Check here for new "Super Pro" bulletin.
- Check here for new Hammarlund "37" General Catalog.

Name
Address
City State

HAMMARLUND'S 25TH YEAR



Now—a high-powered



Radio Engineering Library

—especially selected by radio specialists of McGraw-Hill publications.

—to give most complete, dependable coverage of facts needed by all whose fields are grounded on radio fundamentals.

—available at a special price and terms.

THESE books cover circuit phenomena, tube theory, networks, measurements, and other subjects—give specialized treatment of all fields of practical design and application. They are books of recognized position in the literature—books you will refer to and be referred to often, if you are a practical designer, researcher or engineer in any field based on radio, you want these books for the help they give in hundreds of problems throughout the whole field of radio engineering.

5 volumes, 3064 pages, 2000 illustrations

1. Glasgow's PRINCIPLES OF RADIO ENGINEERING
2. Hund's PHENOMENA in HIGH FREQUENCY SYSTEMS
3. Chaffee's THEORY OF THERMIONIC VACUUM TUBES
4. Terman's MEASUREMENTS IN RADIO ENGINEERING
5. Henny's RADIO ENGINEERING HAND-BOOK

10 days' examination. Special price. Monthly payments. \$25.00 worth of books cost you only \$23.50 under this offer. Add these standard works to your library now; pay small monthly installments, while you use the books.

SEND THIS ON-APPROVAL COUPON

McGraw-Hill Book Co., Inc., 330 W. 42nd St., N. Y. C.

Send me Radio Engineering Library, 5 vols., for 10 days' examination on approval. In 10 days I will send \$2.50, plus few cents postage, and \$3.00 monthly till \$23.50 is paid, or return books postpaid. (We pay postage on orders accompanied by remittance of first installment.)

Name

Address

City and State

Position

Company

NEW!

The Library now comprises a revised selection of books culled from latest McGraw-Hill publications in the radio field.

WORTH DOLLARS

But It's FREE!



This New 1936-1937 Edition of the Sylvania Auto Radio Installation and Servicing Booklet!

More automobile radios installed this year than ever before! . . . Are you set to get your slice of this profitable business? Be sure you are ready to meet it! You can be prepared with this new Sylvania Booklet! Here are a few of the features contained in this valuable book: Elimination of motor interference for every make of 1936 car . . . Tube complement chart for practically all models of automobile radio sets, with I. F. peak frequencies . . . Set and Antenna installation hints . . . Power supply hints, etc. These and hundreds of other problems you will meet in auto-radio installation and servicing are covered in this amazing book.

Fill out coupon below and mail it NOW! You will receive your free copy of this valuable book in a few days.

SYLVANIA

THE SET-TESTED RADIO TUBE

HYGRADE SYLVANIA CORPORATION
Emporium, Pa.

RW-17

Please send without obligation your new service book, "Auto-Radio Installation and Servicing."

Experimenter Amateur Call

Serviceman Employed by dealer Independent

Member Service Organization

Name

Address

City

State

Name of Jobber

Address



IT'S A HONEY ISN'T IT?
YOU CAN'T BEAT ALLIED
MATCHED KITS WHEN
YOU BUILD YOUR OWN!

YOU'LL ALWAYS FIND ALLIED'S
CATALOG LOADED WITH NEW
GEAR AT THE
LOWEST PRICES!

"You Get Better Service and Save Money at Allied"
SAY AMATEURS AND EXPERIMENTERS EVERYWHERE!

—And thousands of enthusiastic Amateurs and Experimenters can't be wrong! No matter what your radio needs are, the entire ALLIED organization is keyed to meet your requirements:

21 expert Amateurs and Engineers to help you select the equipment you need, accurately and economically—to answer your inquiries quickly, in a helpful personal way!

10,000 selected radio items—the cream of Amateur Radio—tested and approved by trained engineers—to assure you of highest quality always—to give you speedier shipment on every order—to make your radio buying easier and more profitable!

ALLIED'S economical merchandising, tremendous purchasing power and efficient shipping methods bring you the finest values in Amateur Radio—quickly and safely—at the lowest prices. You save in time, trouble and money on every purchase when you order from ALLIED—that's why ALLIED is "tops" in Amateur Radio!



TESTING LABORATORY AT ALLIED

A corner of our modern, well-equipped laboratory, where skilled radio technicians carefully test equipment offered in the ALLIED Catalog for quality and performance. Our high standards are your best protection—your assurance of greatest dependability and value!

EVERYTHING IN RADIO AT LOWEST PRICES

If you haven't a new 1937 ALLIED Catalog write now for your FREE copy! It includes more than 10,000 duplicate and replacement parts; 38 models of the new Knight Radios; dozens of Build-Your-Own kits; the latest SW receivers and transmitters; P.A. Equipment; test instruments; Rurlpower units and Winchargers; books, tools, etc. Send for this great book today!

FREE
CATALOG ↓



ALLIED RADIO CORPORATION
833 W. JACKSON BLVD., CHICAGO

ALLIED RADIO CORP. Dept. 16-A
833 W. Jackson Blvd., Chicago, Ill.

Rush me your 1937 ALLIED Radio Catalog.

Name

Address

City State

RADIO WORLD

Fifteenth Year

ROLAND BURKE HENNESSY
Editor

HERMAN BERNARD
Managing Editor

HERBERT E. HAYDEN
Advertising Manager

Table of Contents for JANUARY, 1937

A Low-Cost Oscilloscope 8 <i>New 913 Tube Basis of Simple Device</i> By Herman Bernard	Super with Balanced Detector .. 39 <i>Some Volume Expansion Automatically Present</i> By H. B. Joseph
An Approach to Television 26 <i>Through Understanding of Oscilloscope</i> By J. E. Anderson	A Standard Small Super 45 <i>Provides All You Can Expect of Five Tubes</i> By M. N. Beitman
Defective Volume Control Servicing 27 <i>Tracking Down and Curing the Trouble</i> By Jack Goldstein	A Multi-Purpose Generator 48 <i>Radio and Audio Frequencies Produced; Condensers Tested</i> By Henry Burr
A Simple Audio Oscillator 30 <i>Original Frequencies Generated, with Coil Switching</i> By M. N. Beitman	An Advance in Control Calibration 51 <i>Band Width, Beat Frequency, and Gains Direct-Reading</i> By Donald Lewis
A Small Code Transmitter 32 <i>Crystal Oscillator and Beam Tube Used</i> By Harvey E. Sampson	A Short-Wave Converter for Supers 54 <i>I. F. of 1,600 Kc is Used</i> By Conrad L. Buckwall
Right or Wrong? 33 <i>Posers Put and Answers Given</i>	Radio Construction University 57 <i>Answers to Questions on the Building and Servicing of Radio and Allied Devices</i>
A Transceiving Rig for Testing 34 <i>Calibrated Generator and Receiver</i> By Edgar Lee Wellsworth	Tradiograms of the Month 59
Squeals Due to I. F. Second Harmonics 38 <i>Filtering and Critical Location as Solutions</i> By James Millen	

Vol. XXIX, January, 1937. No. 10. Whole No. 700. RADIO WORLD, published monthly by Hennessy Radio Publications Corporation, 145 West 45th Street, New York, N. Y. Editorial and executive offices, 145 West 45th Street, New York, N. Y. Executives of RADIO WORLD: Roland Burke Hennessy, editor and business manager; Herman Bernard, managing editor; Herbert E. Hayden, advertising manager. Officers of corporation: Roland Burke Hennessy, president-treasurer; Roland Burke Hennessy, Jr., vice-president; Herman Bernard, secretary. Entered as second-class matter March, 1922, at the Post Office at New York, N. Y., under Act of March 3d, 1879.

SUBSCRIPTION RATE

Price 25 cents per copy. Subscription \$2.50 per year (12 issues); \$1.25 per six months (6 issues); postpaid in United States and Possessions; \$3.00 per year, \$1.50 per six months, postpaid in all other countries. Remittance for foreign subscription should be by International money-order (postal or express) or draft against or discountable at New York bank.

RADIO WORLD is distributed by the American News Company and its Branches

So far, by concentration, the stream's impact on the viewing screen causes the appearance of a spot of greenish light.

We have accounted for only half of the elements, K, G, A1 and A2. The others are the deflecting plates, of which one pair deflects the spot in one direction and the other pair in a direction at right angles. The pairs are (D1, D2) and (D3, D4).

THE DEFLECTING PLATES

As we desire to have an image on the screen we use one set of plates to move the spot in one direction and the other set of plates to move the spot in a direction at right angles to the first. The movement across the screen, as if from left to right, for instance, is called the horizontal deflection, represented by the letter H, and the movement up and down is called the vertical deflection, represented by the letter V. Also H = X axis and V = Y axis in another symbolism. Since once each of the deflecting plates is connected to the highest B voltage, only two plates need be considered for input connections, D1 and D3. In this particular tube the two other plates, D2 and D4, are connected together inside the tube, and A2 is also connected the same way, so that the Pin No. 1 connection, made externally, takes care of the positive B return of the deflecting plates and the A2 connection. Also, Pin No. 8 does the same thing, as it is tied to Pin No. 1 inside.

Although either deflecting plate D1 or D3 may be used for vertical or horizontal deflection, it is obvious that all that is necessary is to turn the tube around on its beam axis to change the direction relative to the eye. Therefore it is necessary at least to install the tube so that one input or the other affords a perfectly horizontal or perfectly vertical deflection, and then, if the intended vertical deflection is actually horizontal, and vice versa, the proper relationship is established by transposing the connections to D1 and D3.

SENSITIVITY COMPARED

In this connection it should be borne in mind that the deflection sensitivities of the two plates are unequal, D3 being nearer the screen, having the greater sensitivity.

The d.c. ratings are as follows:

Plates	250 v.	500 v.
D1, D2	.15 mm/v.	.07 mm/v.
D3, D4	.21 mm/v.	.1 mm/v.

The designation mm/v. means millimeters per volt. A millimeter is one one-thousandth of a meter. The greater distance the spot is moved by one volt connected across input terminals, the higher the sensitivity. The larger B voltage produces more brightness, but sensitivity is less.

Assuming full occupation of a one-inch screen, a sensitivity of .15 mm/v. equals 15 mm/100 v., and since there are about 25 millimeters to an inch, for full deflection of one inch the input voltage required is $(25/15) \times 100 = 166$ volts. So .07 sensitivity is half as much and requires twice 166 or 332 volts. The other plates re-

Focus and Brilliance Are Closely Related

The two principal controls on the oscilloscope are those identified as governing focus and brilliance. There is some interdependence of controls in oscilloscopes generally, and in particular there is distinct interdependence in regard to these two controls.

First, the focusing is properly the projection of a spot, roughly referred to as a pinpoint, but seeming nearer the size of the head of a tiny pin, with excellent definition, sharpness of circumference and general uniformity. However, the actual operation is the establishment of the correct ratio between the voltages used for biasing the cathode-ray tube grid (intensity) and for exciting the accelerator or Anode No. 2 (focus). Hence the determination of a given proper ratio between two voltages scarcely could be ascribed ordinarily to a single control, where there are two controls, one for each voltage.

The reason why focusing is definitely ascribed to one and intensity to the other is that there is in general a certain degree of intensity that is found both satisfactory for viewing and respectful of the life of the tube. Hence if a given degree of brilliance is assumed, there remains need of establishing correctly, therefore adjusting, only the other, and in that sense the focusing function is properly assigned to the one control and the manipulation for intensity or brilliance to the other.

It will be found in practice that about the same intensity control position will be utilized time and again, but that the focus may be adjusted more frequently, especially as it is affected by the impact of electrons, and changes of input voltages for examination will require readjustment of focus, and sometimes of brilliance, too.

quire for the two cases 119 volts (.21 example) and 250 volts (.1 example).

It can be seen that the D3, D4 combination is consistently about 1.4 times as sensitive, or has about 20 per cent. greater sensitivity. This fact is important to consider if you are getting too much deflection in one direction compared to the other, when reversal of the connections to D1, D3 will aid, or mechanically the tube's physical position would have to create a 90-degree change in the relative deflection directions.

MOVING THE SPOT

We left the beam as a spot on the viewing
(Continued on following page)

(Continued from preceding page)
 screen in our discussion of the performance of the tube. Now we have to consider the shifting of the spot in one direction and the other. First let us consider the vertical movement. If we have the spot centered on the viewing screen, or approximately so, with no input to the deflecting plates, and if we introduce a relatively small a.c. voltage at the V input, there will appear a series of dots, representing the spot moving slowly upward, returning to the natural spot position, then moving downward, then returning to the zero point again, and moving upward to repeat the cycle. This occurs because the alternating a.c. voltage is not a constant voltage, but rises from zero to maximum positive or

age applied to the V posts we shall move the spot with greater rapidity than enables us to distinguish separate spots, and then we have still a series of spots, but the spots are so close together that the retention seems continuous and the spots appear to the eye as a line. Hence with a high enough frequency, and the 60-cycle frequency of the a.c. mains is high enough, the spot we started with suddenly spreads into a line reaching equally above and below the original spot position.

Suppose the spot actually travels a greater distance upward than downward. This would be true if the wave were distorted, not a pure wave, or sine wave, but of greater amplitude during one half cycle, or alternation, than dur-

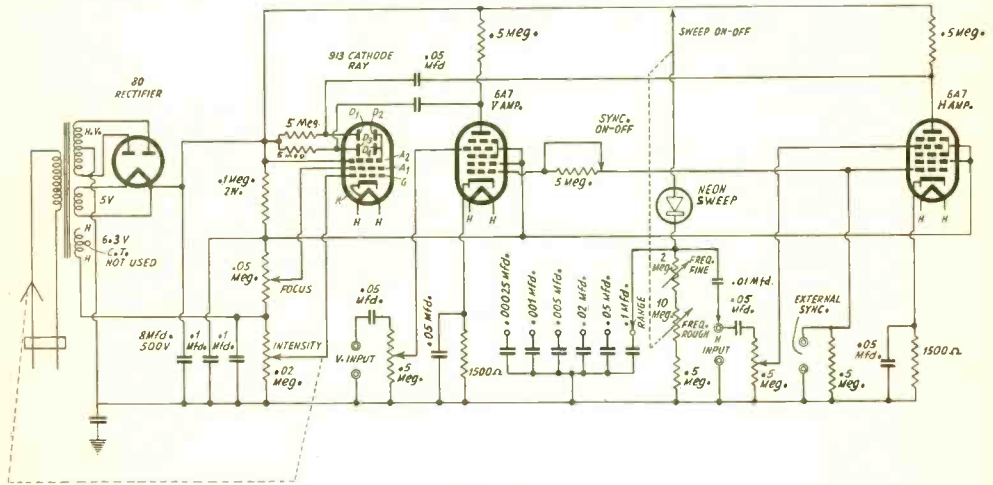

FIG. 2

The circuit diagram of the complete oscilloscope, using the neon tube as sweep oscillator. Two switch controls may be ganged, as shown. One rheostat, of 10 meg., normally would provide enough resistance in circuit, before the attached switch opens, to permit dispensing with the .5 meg. fixed resistor shown in series with that rheostat. The 10 meg. rheostat is special and not normally stocked by supply houses. The grounding condenser, lower left, is .1 mfd., 600 volts.

peak, returns to zero and falls to maximum negative or peak, then returns to zero again, and repeats the performance.

If the frequency is low enough, say, 10 cycles per second or less, the separate spots are seen, although there is only one spot, and it is being moved slowly. The duration of the spots in the human eye accounts for the appearance of a series of them. That is, the eye, viewing a slowly moving spot at a given instant, retains the image of previous spot positions for a short while, so one seems to see several spots where only one spot exists. This phenomenon is not confined to spots alone but to all seeing and is called persistence of vision.

Because of this faculty, 24 still pictures a second as shown in the movies create the illusion of motion, when each still represents some different position of an object photographed when in motion. To avoid flicker, the number of pictures per second in the movies is made 24.

DEFINITION OF LINE

So if we increase the frequency of the volt-

ing the other. We would not be able to tell this from mere inspection of the perpendicular or vertical delineation, without remembering just where the spot was originally.

Our eyes and memory alone are not reliable enough as measuring instruments, and so we consider the horizontal deflection, which spares the necessity of resorting to memory, at least.

The movement of the spot along the horizontal plane is exactly the same in principle as the movement of the spot vertically. But if we combine the effects of moving the spot vertically and horizontally, and preferably make the horizontal movement slower than the vertical movement, we move the spot both vertically and horizontally and produce a trace.

If we draw a sine wave on a given axis, a small part at a time, using a pencil, we shall note that the pencil is being moved both horizontally and vertically, i.e., the pencil is moved constantly to the right, to establish different horizontal distances from the start. Naturally there must be a slant to the line to accomplish the wave representation, but the slant

LIST OF PARTS

Coils

One power transformer, 115-volt primary; three secondaries, one of 5 volts, 3 amp., one of 6.3 volts, 2 amperes; the third of 350-0-350 (H. V.)
Four .1 mfd. paper dielectric (Cornell-Dubilier). One is not marked for capacity in diagram,

Condensers

One 8 mfd. .525-volt electrolytic (Cornell-Dubilier)
but is common ground
Six .05 mfd. (Cornell-Dubilier)
One .01 mfd. (Cornell-Dubilier) This may have to be a bit higher in capacity for sufficient sweep deflection
One .02 mfd. Cornell-Dubilier)
One .005 mfd. (Cornell-Dubilier)
One .001 mfd. (Cornell-Dubilier)

Resistors

One .1 meg. 2 watts (International Resistance Co.)
One .05 meg. linear potentiometer (I.R.C.)
One .02 meg. linear potentiometer (I.R.C.)
Two .5 meg. linear potentiometer (I.R.C.)
One 2 meg. potentiometer (I.R.C.)
One 10 meg. potentiometer (I.R.C.). This is not carried by supply houses, but is ordered specially by jobbers and is usually obtainable by them.
Three .5 meg. fixed (I.R.C.)
Three 5 meg. fixed (I.R.C.)
Two 1,500 ohm fixed (I.R.C.)

Other Requirements

One RCA 913 cathode-ray tube
One 80 and two 6A7 Sylvania tubes
One neon tube without limiting resistor built in ($\frac{1}{4}$ -watt sufficient)
One single-deck six-position switch
One octal socket, one four-hole socket and two seven-hole medium sockets
Two switches, SPST (may be affixed to controls as diagram on opposite page indicates)
Two grid clips
Two separate SPST switches (synchronization and internal sweep on-off)
Six knobs (eight if two switches are not teamed with controls)
One chassis. One panel. One metal box
Six binding posts

arises from the changes taking place in two directions at right angles to each other.

RELATION OF TWO FREQUENCIES

Instead of the pencil used in the analysis we have in the oscilloscope a spot, moving at the same time across and up and down on the viewing screen, therefore the spot replaces the pencil, and traces the wave form of the a.c. voltage injected at the V posts. The lower the frequency of the voltage used for horizontal deflection, the fewer repetitions or cycles of the wave that will appear on the screen, until when both frequencies are the same, there is only one wave on the screen, a complete cycle. We could show also a half cycle, quarter cycle, etc.

Now with the V wave on the screen, seen as standing still, we view one or more cycles, and can readily tell whether the positive and negative alternations are equal, or, if unequal, which is the greater. This, however, is only one of a great number of services that the cathode-ray oscilloscope can perform.

There is wide latitude as to the V input, as is to be expected, since to the V posts is connected the unknown that is to be viewed and studied. The wave shape may be almost anything, the

amplitude has wide scope, there may be modulation present or absent, d.c. superimposed or not, and numerous other variations. With the horizontal or H input, however, the situation is quite different.

To permit the appearance of the wave in the manner in which we are accustomed to observe it, the frequency for the horizontal excitation should be lower than the frequency put into the V posts, and it is handy to have the H frequency a submultiple of the V frequency. Thus if the V frequency is 60 cycles, the H frequency may be 20 cycles, and there will appear on the viewing screen three complete cycles.

SAW TOOTH REQUIREMENT

Moreover, the horizontal frequency cannot be of any and every wave shape. If it is a sine wave then the screen will show a double image, one represented by the positive ascension, the other by the negative declination of the horizontal frequency's wave. To get around this difficulty the frequencies for the horizontal deflection are obtained from a special oscillator that generates a particular kind of wave form, called saw tooth, because when viewed, the suc-

(Continued on following page)

(Continued from preceding page)

cession of waves look very much like the teeth of a saw, an oblique rise from zero to maximum, then an almost perpendicular drop to the zero axis, and return to the starting point, a practical half wave. The negative, or return sweep, is negligible, and therefore we do not see confusing double images when there is wanted only a single image of one or more cycles. The saw tooth oscillator therefore is a necessity, and is usually built into the cathode-ray oscilloscope, using either a thyratron gas-discharge tube with control grid, or a gas tube without control grid, such as the neon tube.

LINEARITY OF H CURRENT

Another point regarding the horizontal frequency wave is that it should be linear. Specifically, the current should change uniformly with time. Ordinarily the gas-discharge tubes don't quite provide oscillation waves of this type, but special means may be provided to establish a fairly good approximation of linearity or indeed make linearity nearly perfect.

When there is complete linearity each wave of the V frequency being analyzed has the same width on the viewing screen, but when linearity is absent, the waves have unequal widths, becoming more and more crowded nearer on one side of the screen or the other, depending on the tube's physical position.

Linearity is established by using a current-limiting tube, for instance a saturated pentode or diode. A tube is saturated when all the electrons emitted by the cathode are drawn over by the anode. Hence if voltage input to the tube is increased, no current increase results, as the current already is all it can be. So the saturated tube, used as a series limiting resistor in the saw-tooth oscillator circuit, tends to hold the charging current uniform, and hence the voltage across the condenser that is being charged rises linearly.

GOOD APPROXIMATION

The method of using the saturated tube does not find much commercial application, because of the advisability of its operation from batteries for best results, and because it represents another tube to be included and voltaged. Complete linearity is not actually essential. A good approximation is sufficient for service purposes.

Also, if several cycles are purposely put on

SERIES RESISTOR HELPFUL

IS it advisable to use a series resistor, and if so of what value, leading from B plus serving detector and audio tubes, to B plus for the i.f. and r.f. tubes?

Yes, this is good practice. Around 2,000 ohms suffice, usually, and of course a bypass condenser, preferably of paper dielectric, say, .25 mfd., should be placed between the r.f. or i.f. side of the resistor and B minus. This practice is particularly helpful if the r.f. or i.f. circuit oscillates. Of course, if the oscillation is intense, and therefore very serious, additional precautions might have to be taken, if the trouble is to be eradicated completely.

the viewing screen, say at least three, then one may be viewed critically and the two others ignored, or two may be observed closely, and the one other ignored. Since the crowding is progressive, that part of the pattern where the crowding is worst need not be used for study.

Now, the frequency produced by the saw-tooth oscillator should be a submultiple of the unknown that is being studied, and since the unknown may be almost any frequency, the saw-tooth oscillator should have a wide frequency range. There is no trouble at the low frequencies, in fact, a fraction of a cycle is easily attained, but the tubes have a high frequency limit, the neon being about 100 kc and the thyratron much higher.

CLOSE ADJUSTMENT

The generator of the horizontal frequency is called a sweep oscillator, because its voltage is made to sweep the spot across the screen in the general direction that a broom is wielded, and of course the frequency must be adjustable. Moreover, it should be possible to make a very close adjustment. The change in frequency may be accomplished by adjusting the d.c. voltage, the resistance and the capacity, or a combination of two or all three of these options. At least there should be a rough adjuster and a fine adjuster.

It would be possible to get 250 volts from the saw-tooth oscillator of either type, by applying that high a d.c. voltage, but then it would be necessary to take off the full voltage, and linearity is served by taking off less than the full amount, in fact, around 5 per cent. would be quite favorable, for then the time taken for the voltage to rise to that height is not far different than the time taken to descend from that height to zero axis and starting point, although during much of the time the spot is not on the screen, because 95 per cent. of the generator is not represented, and for low H frequencies there is flicker. This is not a vice, as even photography can be performed well. Moreover, flicker does not mean the image is moving, i.e., creeping. The image is standing still.

Because of the small voltage thus extracted from the saw-tooth oscillator, an amplifier is required, and if the gain is 40 and the input volts are 6, the output volts would be 240 volts, or about enough to occupy the screen totally from left to right.

LIMITED OCCUPATION

Also, since low unknown voltages will be used at the V input, an amplifier is necessary, and again a couple of hundred volts or so would be needed to cause the deflections to go all the way up and down on the screen.

It is not desirable, however, to have such a high percentage of image-to-screen ratio, because the screen is viewed through a curved glass that is part of the tube, and the edge effect, called spherical aberration, makes the image look rounded there, and thus gives it a false picture. So lesser gain is used, until the image takes up a sizeable part of the height and width, the operator making his own choice

(Continued on page 14)

Thyratron Sweep Oscillator in More Elaborate and Expensive Rig

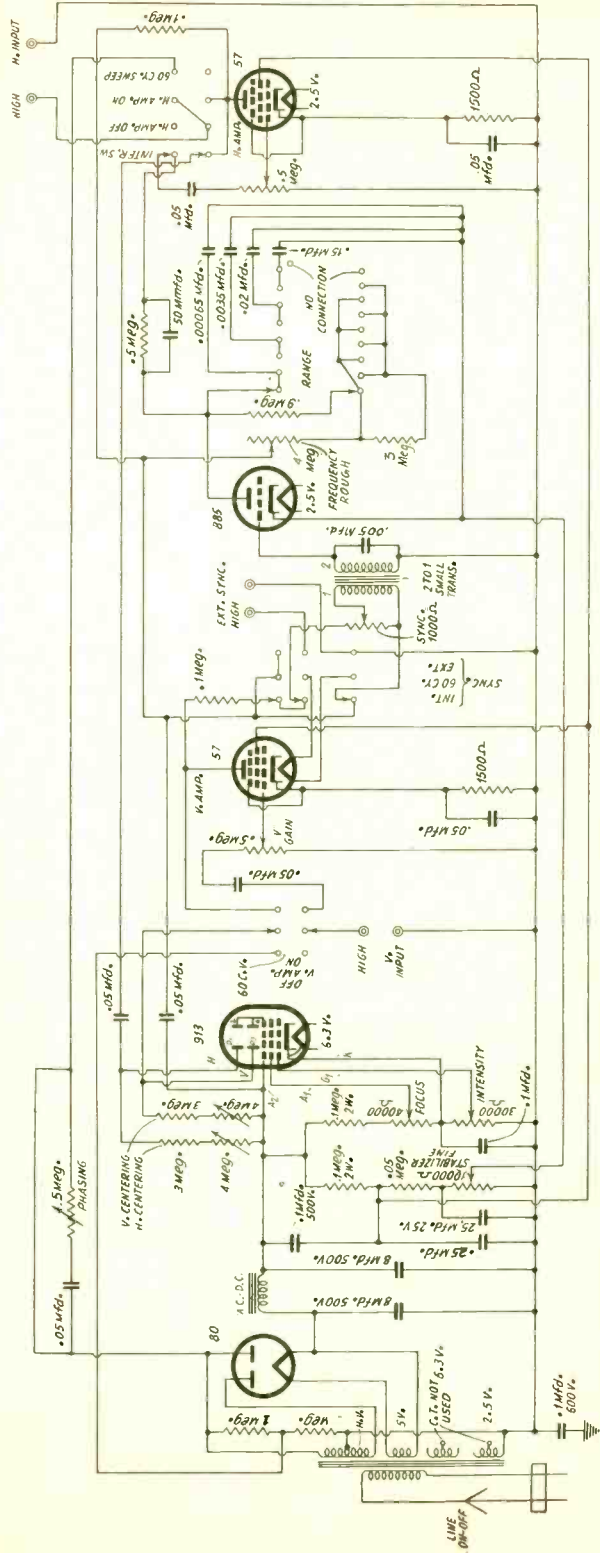

FIG. 3

A more elaborate oscilloscope than the one shown in the previous diagram. This, too, uses the 913 but in general has the equipment found in the larger oscilloscopes, using the 906 tube. This circuit, in fact, is applicable to the 906, in general by using the 80 as a single-wave rectifier, thus doubling the B voltage, and doubling the resistance values in the two bleeder circuits. The lower-positioned resistor at HV is .25 meg, not marked numerically in diagram.

(Continued from page 12)

by gain control adjustment, so certainly there is termination on the screen in both directions.

There is no danger to the tube if the image is made so large that it does not terminate on the screen at all, and indeed there is one particular instance when the sweep is made purposely so wide that it does run off the horizontal axis. This is when instead of the saw-tooth oscillator, a 60-cycle input is used from the line, for this is not saw tooth of course, but practically sine wave, producing "double exposure," but, as with the saw-tooth oscillator, if only a small part of the total voltage is used there will be an approach to linearity, and in this instance it is easier to let the sweep outrun the screen's di-

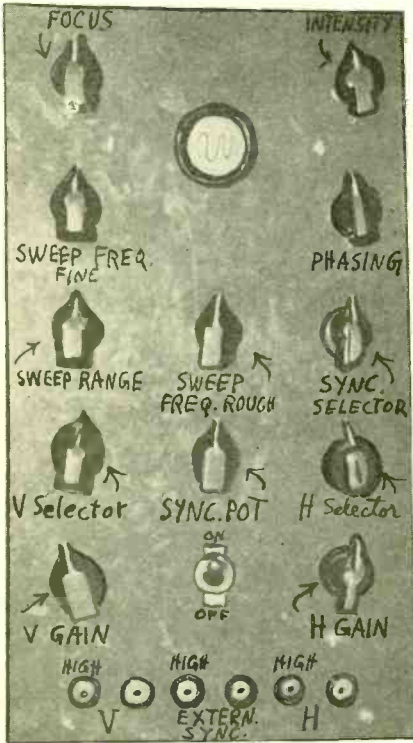

FIG. 4

mensions, and in fact use less than the full voltage by looking at less than all of it.

We have seen that we need amplifiers, therefore one each is customarily provided, and, just as we left the V posts free for any type of unknown a.c. input, so we might want to provide some external H or sweep a.c. voltage, hence include posts for external H input, although principally the sweep voltage will be taken from the gas tube's amplifier.

However, we have not quite finished with the relentless precautions. We considered the requirements of the sweep circuit, and this is the one circuit that gives the most concern, but if we had looked at a 913 screen in a circuit in which only the stated precautions had been practiced we would have seen an image that was moving off the screen. Now, unless photogra-

phy is to be one of the prime purposes of the oscilloscope, some small movement or drift of the image is of no consequence, but considerable drift would be experienced unless some means of overcoming it were introduced. This means consists of putting some of the a.c. voltage of one circuit with the other, usually a little H frequency voltage into the V circuit. It may be done anywhere, even at the vertical deflecting plate input, but it is well to inject a little of the sweep voltage into the V amplifier tube. Usually about one volt or so thus translated is sufficient to achieve the purpose, which is to produce interlock.

It is sometimes difficult to have the H frequency exactly a submultiple of the V frequency, but this problem is simplified when there is some mixture of the two, whereby the higher impedance circuit will hold the other in step with itself, or out of step by multiples or submultiples.

Granted the cathode-ray tube is properly installed and voltaged, and the other considerations just set forth have been followed, we have an operating device and can view transient and recurrent phenomena, i.e., being unable to see what moves too fast for the eye to follow, we have an instrument that establishes a difference, whereby that difference is viewed as a stationary wave. There are many more uses, but wave-viewing is a simple and important purpose, hence excellent to consider primarily.

SUMMARY OF MAIN POINTS

What has been set forth thus far may now be summarized.

1. The cathode-ray tube emits electrons from the cathode, which the other elements control, so that a spot of light is produced that may be moved in two directions in quadrature. The first four elements, K, G, A1 and A2, comprise the electron-shooting and aiming device, or electron gun, and the four others, deflecting plates (D1, D2) and (D3, D4), move the bullet-beam.

2. Into the respective pairs of deflecting plates are put two voltages, one the sweep voltage, for horizontal deflection of the spot, the other the unknown, for vertical deflection of the spot. The combined activity results in a trace.

3. There are certain rigid requirements for the sweep circuit, or H deflection.

a. The sweep frequency should be a submultiple of the unknown frequency.

b. The shape of the H frequency wave should be saw tooth, to avoid "double exposure."

c. The saw-tooth oscillator should be linear, or nearly so, to attain equal or nearly equal widths of each cycle on the viewing screen.

d. The image should not fully occupy the screen.

e. Amplifiers are required, one stage for the H voltage, one for the V voltage.

f. A small part of one voltage should be supplied to a circuit carrying the other voltage, to produce lock-in, whereby the wave is made to stand still on the screen, and not produce a merry-go-round effect.

BESIDES the simple, low-cost oscilloscope so far considered one was built, also using the 913, but with circuit much like that used for larger tubes, such as the three-inch 906. In the more elaborate circuit, where the switching and controls generally the same basis as found in large outfits, because from the single rectifier and voltages and the lower price of the small tube, there is a saving of about 30 per cent. or so in cost. Thus the device is in the \$50 class.

The diagram of the more elaborate circuit is shown in Fig. 3. The front-cover illustration, also Figs. 4, 5 and 6, are of this device, although the other takes the same general physical form.

A few pointers will be given about the diagram of the more elaborate oscilloscope.

TWO VOLTAGE DIVIDERS

Starting from the left, we find the primary of the power transformer. A separate switch is used for turning the power on and off. The

oscillator is used, this particular bias control is used for stabilization and also incidentally for fine adjustment of frequency. The bypass capacities are large enough to prevent any serious interaction.

The horizontal and vertical centering of the spot is affected somewhat by the value of resistance loading the input plates of the 913, therefore two fixed resistors of 3 meg. are included, and two resistors in series with them are shown as 4 meg. variables. Actually, the correct resistance is obtained experimentally and then left in circuit, so that these apparent variables may be considered thereafter as fixed. Their effect on the spot position is not great, but sufficient to be of some aid, because mainly the object of adjusting the resistance is to avoid line slants.

THYRATRON SWEEP OSCILLATOR

The 80 and the 913 have been accounted for, and there are three other tubes, the 885 oscillator and the two 57 amplifier tubes. Hence

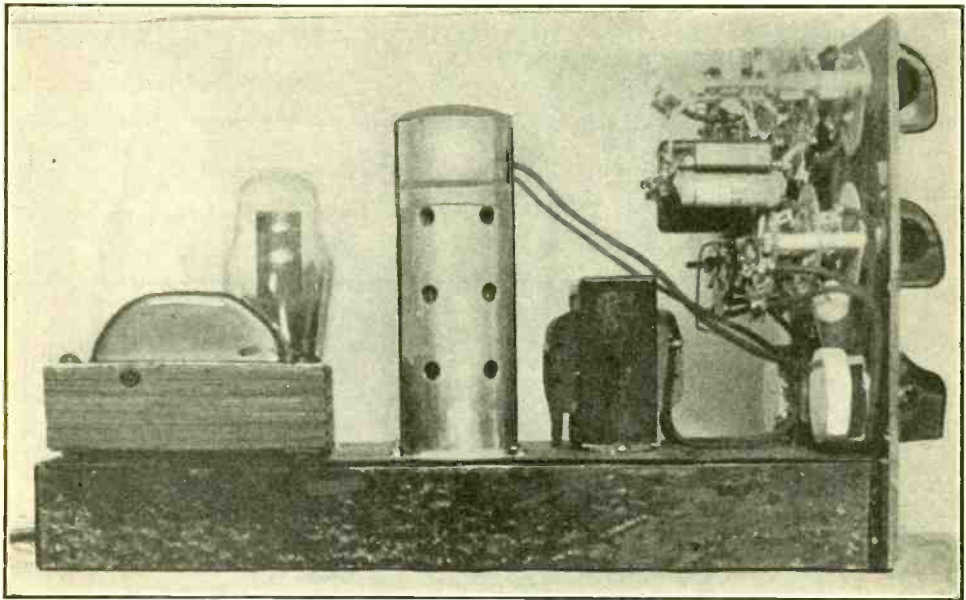

FIG. 5

Looking at the more elaborate oscilloscope from the side. The general layout is approximately the same for the simple oscilloscope and the one shown above, the physical size being no different. Fewer controls are used, with less switching, on the low-cost model, and a neon tube replaces the 885.

rectifier is an 80, used full-wave fashion, and a small B choke is included in the positive leg, the familiar little a.c.-d.c. type of choke, so-called because popular in midget sets that work on both a.c. and d.c.

There are two voltage dividers, one for the usual provision of anode No. 2 voltage and for the focusing and intensity controls, the other for intermediate B voltage, as for screens of the amplifier tubes, and adjustment of the bias on the sweep oscillator tube. Since it is required that there be a rough and a fine control of sweep frequency, when the internal saw-tooth sweep

here we use the thyatron for saw-tooth generations, and by high resistance loading we make the operation, while not perfectly linear, at least closely enough so for satisfactory service.

Provision is made for separate input to either amplifier, as usual, but also for input to the cathode-ray tube direct, without use of amplifiers, as where the input voltages themselves are sufficiently high. The circuit is not applicable to d.c., for the direct input in each instance is made through a stopping condenser.

Taking the vertical input, which is switch-

(Continued on following page)

(Continued from preceding page)

controlled to provide 1 = 60 cycles direct; 2 = amplifier off, V voltage obtained externally; and 3 = amplifier on, V voltage obtained externally. The first 57 tube is the vertical amplifier, in use at only one, the very last, of these three possible positions.

Next is the 885 tube. This uses a 9-position, 2-deck switch for range selection, by picking up fixed condensers of designated values. In association with these condensers are resistors for establishing the time constants on which the frequencies generated largely depend. There are a variable 4 meg. resistor, used for rough frequency control, and a two fixed resistors, one of .9 meg. and the other of 3 meg. The frequency control, and two fixed resistors, are such as to bring them into play alternately.

While not apparent from mere inspection of the 885 circuit, the biasing as obtained largely from the bleeder circuit at left has, as already pointed out, an effect on sweep frequency.

SYNCHRONIZATION CONTROL

The 885 differs from the neon tube in several particulars, one being that the thyatron has a control grid. In this grid circuit is connected a small transformer of 2 to 1 ratio, or lower ratio, the orders of the ratio terms being designated on the diagram. The transformer, because of its free secondary, permits connection to various circuits and potentials.

The switching associated with this transformer has to do with synchronization, or lock-

ing in of the two frequencies, oscillator and unknown, to make the image stand still. The synchronization selector permits of 1 = internal synchronization; 2 = 60 cycles; and 3 = external. By internal synchronization is meant that some of the 885 sweep voltage is mixed with the vertically deflected voltage. This is accomplished by putting the secondary in series with the plate load of the V amplifier tube.

The amount of synchronization is controlled by the 1,000-ohm potentiometer. If there is over-synchronization a line may appear thick, and not uniform. Also, danger of under-synchronization exists, apparent if the image can not be made to stand still, and then a solution would be to use a lower plate load resistor than .1 meg. or not resort to a potentiometer of quite such low resistance. Another possibility is to reverse the connection of the coupling transformer, if making an image stand still turns out to be almost impossible. However, no decision should be made in this respect until the oscilloscope has been used for a week or so, unless one is an experienced operator, because adjustments that control fixation of image are not always finely enough made by beginners.

TIMING VOLTAGES

The second position for synchronization, namely 60 cycles, picks up the 2.5 volts of the amplifier heaters. For that reason the 2.5-volt winding has one side, not center tap, grounded, or connected to B minus really. The actual

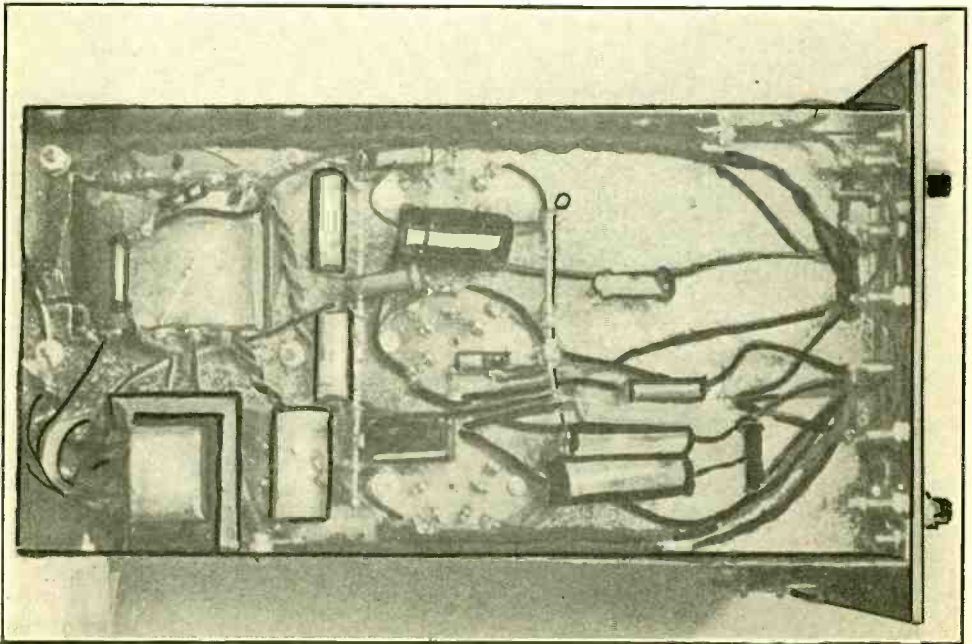

FIG. 6

Bottom view of the parts, chassis and wiring of the more elaborate oscilloscope.

grounding of returns is through a common .1 mfd. 600-volt condenser, lower left.

The third position is for external synchronization, and anything, even 60 cycles, may be connected there. It is common practice to use a transformer connected with primary to the line, 2.5 to 10 volts or so secondary to the external synchronization input, though proper choice of constants of the coupling transformer in the present oscilloscope, should dispense with the need of otherwise obtaining 60 cycles for this purpose.

The remaining multi-switch has to do with timing, or production of the horizontal wave. The switch positions are 1 = internal sweep; 2 = horizontal amplifier off; 3 = horizontal amplifier on; and 4 = 60 cycle sweep. The internal sweep is provided by the 885, the horizontal "amplifier on" provides amplification from the 57 H amplifier, while "off" provides connection direct to the cathode-ray tube, but not for d.c., as there is a stopping condenser in circuit. The 60-cycle timing frequency is obtained directly from the secondary of the power transformer. The resistance values have been selected so that the length of the line will be ample even when the H gain control is not nearly full on.

In two instances 60-cycle operation has come up, and they are quite different in purpose. In the first instance we considered 60-cycle synchronization. This means that the 60-cycle pulses, however obtained, are united with the V and H waves so that there will be locking in at 60 cycles and multiples of 60 cycles, up to, say, 600 cycles.

SYNCHRONIZATION VS. SWEEP

Thus a sizable voltage may be obtained readily, from the line through a transformer, or from the oscilloscope supply, with the only restriction that locking is assured for multiples of 60 cycles only, up to a certain limit, say, tenth harmonic of the synchronizer. The service is valuable when and if the other locking-in attempt does not materialize, and when there is no restriction imposed by the analysis being undertaken that the frequencies must be other than multiples of 60.

However, since the H input posts are free in two switch-position instances, obviously any kind of a.c. voltage may be injected, including 60 cycles, but it is convenient to obtain the 60 cycles from within the oscilloscope. This is not a locking purpose at all, but the provision of a 60-cycle sweep, to supplant for the time any other sweep. It is not a linear sweep and its purpose is rather to permit access to a.c. of different phases for rapid production of patterns, without external equipment, and for obtaining, if desired, some approach to linearity, by grossly overdoing the input to the horizontal deflecting plates—without overloading the amplifier tube, which for such safety is then not in circuit—and using only so much of the total available 60-cycle voltage as to reject the amplitudes where the departure from linearity is severest. It will be remembered that linearity is not an adamant requirement, but that some

approach to it is requisite for most purposes, that the normal sweeps are not completely linear, also the modified linearity of the 60-cycle sweep, used as described, will be much less than that from the thyatron sweep.

A rheostat of .5 meg. shunting a condenser of .05 mfd. provides a means of shifting the phase of the voltage input to this 60-cycle sweep, and is identified on the front panel imprinting as "Phasing." The minimum setting of the control should represent some resistance.

Naturally, when 60-cycle sweep is used, and 60-cycle V input as well, there is no need for lock-in, as the two frequencies are the same and from the same source. If the phases are not unity, that is probably just what one desires, because phase patterns are to be viewed, but if it is desired to have the voltages in phase, this may be accomplished through adjustment of the phasing control. Sometimes the gain control has to be worked conjunctively, as it may have a small effect on phase.

The 885 socket connections are the same as those for the 27, 56, 76 and other triodes of this glass-tube group.

II.

CONSTRUCTIONAL FACTS

PROCEEDING now to the construction of about the simplest practical oscilloscope, we find that we need, among other things, a rectifier circuit to deliver between 250 and 500 volts d.c. There is a bleeder circuit consisting of three resistors, of which two are potentiometers for intensity and focus and one is a fixed resistor.

We find it necessary to choose suitable constants for the rectifier and bleeder network. Almost any of the power transformers used for small sets will do. Ordinarily a small set will provide, under its accustomed load, some 275 volts d.c., but here the B drain will be less, there is no choke to reduce the voltage, hence we may expect a voltage of around 300 volts or so. This is close to the lower B voltage limit, but favorably so, in one sense, because the sensitivity is increased about in proportion that the B voltage is decreased. At the same time the brilliance is less, but there is plenty to spare, as the illumination is excellent, due to a husky cathode, a sensitive fluorescing substance, and the short travel distance of the electron stream, due to the small size of the tube. The size is about that of the metal power tubes, and the base fits the regulation octal socket.

The bleeder current has to be sufficient to enable independence of the two controls, intensity and focus. The knob that is meant for focus adjustment should not play any considerable part in determination of brilliance, nor should the intensity control cause change of focus. Hence a .1 meg. resistor, 2 watt rating, is used for reducing the maximum B

(Continued on following page)

"Oscilloscope" Preferred Word to "Oscillograph"

Throughout this article the word *oscilloscope* has been used consistently, rather than *oscillograph*, although there is respectable precedent for the use of either. Etymologically, *oscilloscope* is preferable, because the instrument as used in servicing in particular is not for recording, in the sense of making a permanent record, but of viewing.

The words that connote recording often have the suffix *graph*, from a Greek word meaning to write, while words ending with *scope* refer to observations, from another Greek word, meaning to view.

Since viewing, rather than recording, is the main objective, the word *oscilloscope* is deemed preferable. However, as soon as photographs are taken, or tracings made on transparencies or translucencies, the word *oscillograph* would be preferable, if the recording means is then considered a part of the instrument. Also, the recorded pattern would be referred to as an *oscillograph*.

(Continued from preceding page)

voltage to a value suitable for Anode No. 1, when the control of this anode, which affects focus, is at a position for its highest voltage, which may be 40 per cent. of the full voltage capability of the rectifier. This intermediate B voltage, by the way, is sufficient for the screens of the amplifier tubes.

THE SPOT APPEARS

The intensity control should work effectively over a sensible part of its range, although it is all right for the screen to be dark over some part of the displacement of this control. This is the one that controls the grid bias. Focusing should permit reduction of the width of the line or size of the spot to a hair or a pinpoint, and in general the breadth should be as small as is consistent with ease of viewing.

Two resistors of 5 meg. each are shown connected from each free deflecting plate to B plus, hence to the other or return deflecting plates. Their object is to prevent the building up of spurious d.c. voltages on the deflecting plates. The values are suggested at 5 meg. but may be from 1 meg. to 10 meg., and different, on the basis of experimental finding.

When the circuit is hooked up with rectifier, cathode-ray tube, stabilizing resistors, B bleeder circuit with the two controls for focus and intensity, a spot should appear. Nothing need be connected by way of input to either free deflecting plate, D1 or D3, as the spot is the result of the electron beam striking the viewing screen.

Hence the first consideration in obtaining satisfactory operation is to establish suitable spot location.

SPOT CENTERING

In general, the spot may be expected to be found somewhere near the center. Change in d.c. voltage will cause displacement of the spot to some other fixed position. If the B voltage to one return deflecting plate is increased the spot will be raised or lowered vertically, say, and if the spot is being lowered when one wants to raise it, either the voltage should be changed in the opposite direction to the former trial, or the tube position may be rotated 180 degrees about its axis. That rotation, however, would also affect the spot horizontally, in case a change has to be made on this plane, too, and would alter the direction in which the spot has to be moved for the H position. There is nothing to be gained by such tube rotation, unless only one direction of change has to be introduced. Also, once the tube is installed, the change in position is no easy matter, because of socket fixation and the position and length of accompanying wires.

The voltage change may be introduced directly, by including polarizing batteries, or by dividing the B supply, or indirectly, by using different values of stabilizing resistors within the prescribed range of .1 to 10 meg., for the d.c. voltage on the deflecting plates is higher, the lower the value of stabilizing resistor. This use of the limiting resistors for spot positioning is incidental to and may conflict with their main purpose.

Having the spot somewhere near the center is desirable, although exact center is not vital. The operator has some freedom of choice in this respect.

A SERIOUS PRECAUTION

While it is desirable to reduce the spot to a small size, like a point of light, which can be accomplished by proper manipulation of the two controls, brilliance and focus, *under no circumstances should the spot be left on the screen any longer than absolutely necessary to make the adjustment*, and for not more than several seconds. If any serious duration is permitted, the spot will cause deterioration of the fluorescent substance, and there will not be as much illumination at this spot position as over the rest of the picture you are to see later.

Since there is no moving voltage deemed present or accessible yet, because no input has been provided to the free deflecting plates, the spot may be moved sufficiently, when time is up, by turning off the a.c. supply to the oscilloscope. Then the spot will travel off the screen obliquely and the switch is turned on again to shoot the spot back in place. However, a very few seconds must suffice for preliminary establishment of the proper spot size. It might be preferable to wait until a deflection supply is ready before trying out the spot position, focus and intensity, so motion can be quickly provided.

The input to the V amplifier is made through

a stopping condenser, the voltage being developed across a .5 meg. potentiometer. The moving arm goes to grid of the vertical amplifier tube. If this tube is a 6A7, the pentode section serves as amplifier, the triode having its effective plate tied to the intermediate B feed, while triode grid is connected to the equivalent element of the horizontal amplifier tube, the common return being to minus through a fixed resistor. A high resistance between the two G₁ terminals of the amplifier tubes practically stops the lock-in coupling, unless shorted out. This is a switch control. Posts at the terminals of the common load resistor permit access to the lock-in circuit for external synchronizing voltage.

THIS ONE FOR A.C. ONLY

With amplifiers and relaxation oscillator wired in, the oscilloscope is now for a.c. input to both horizontal and vertical circuits, since the stopping condensers prevent the application of d.c. to the amplifiers' input, and besides the amplifiers themselves do not amplify d.c. If the d.c. is pulsating it may be treated as a.c. so far as input and amplification are concerned, although the pattern to appear on the screen will not be full-wave.

Since the vertical voltage is obtained externally, and is the unknown to be examined, no special attention need be paid to it, save that one should not put in any very large voltage, with potentiometer arm advanced to maximum input, or the amplifier tube will be overloaded. It is well to start with the two gain controls at zero input, and slowly turn them for increased input to the control grids of the amplifiers.

The sweep frequency oscillator, shown as a relaxation oscillator, using a neon tube, has two adjustable resistors, one of 10 meg. and the other of 2 meg., for rough and fine frequency control, respectively. Also there is a fixed limiting resistor in the series network. The range of frequencies is established by switching in one of five fixed condensers across the limiting resistance. The frequency variation for any given capacity setting is established by changing the resistance, until the image is a continuous design and reveals a sufficient number of cycles on the screen. Three or four cycles would be ample, but often it is necessary to get along with fewer.

The focus and intensity adjustments may have to be remade after the unknown and timing voltages are introduced, and of course the gain controls are manipulated so that the image is well within the physical limits of the viewing screen.

SEEING SOMETHING INTERESTING

Perhaps the first test one desires to make is an examination of effects obtained from the a.c. line. The high V input post may be connected to one side of the line, the relaxation sweep introduced, and the gain controls worked until the image is of proper size. The image should be that of a sine wave. Queer patterns result until adjustments are right.

While there is synchronization between the

Return Sweep Rated As Severe Nuisance

The saw-tooth oscillator is commonly used for sweep or timing purposes in an oscilloscope because the current rises from zero to peak value slowly, and declines almost abruptly, whereupon the cycle repeats itself, and there is in effect half-wave excitation. Normally the return sweep, or back wave, is not seen for this reason. But under some circumstances it might appear. First suspicion of its presence may be aroused by the fact it is fainter than the front wave, and may depart greatly from the symmetry of the front wave.

So important is it to avoid the return wave's presence on the viewing screen, where saw-tooth sweep is intended, that if it is objectionably noticeable, a voltage of equal frequency, but different phase, is introduced, so that it will balance out or neutralize the return pattern. The reason, of course, is that the presence of the return sweep as a part of the pattern is confusing, if not baffling, especially when the figures are complex, but for low frequencies, say, in the audio spectrum, little trouble on this score need be expected.

If the return sweep is present, but not identified as such, errors as great as 50 per cent. may be suffered, if indeed it becomes possible to reach any determination whatever.

Should one possess a sweep oscillator of known low return sweep, practically negligible, another sweep oscillator may be checked against it, for the pattern of the unknown will appear, and may be examined for the intensity and shape of the return wave.

When a.c. of sine wave or other such type is purposely introduced, the considerations just set forth do not apply, e.g., to compare the phases of two waves of equal frequencies.

sweep and the vertical input, due to common grid circuits of the amplifiers, it may not be sufficiently effective to prevent image drift, whereas addition of external 60-cycle synchronizing voltage should accomplish stability fully. The line frequency will tend to take control as lock-in.

This 60-cycle input to the external synchronization posts can not be obtained from the 6.3-volt winding, because of the positive d.c. potential derived from the B supply, as the 913's cathode is at this d.c. potential and is tied to the heater inside the tube. It is, however, possible to connect a .05 mfd. condenser from one plate of the 80 rectifier to the high

(Continued on following page)

(Continued from preceding page)

side of the external synchronization post, and this same method may be used for input to the vertical post.

Also, 60 cycles may be put into both H and V posts, and controls worked until there are queer patterns like loops, figure eights and bracelets. These represent phase differences.

RANGE OF INSTRUMENT

By using the sweep circuit built into the oscilloscope, and introducing line a.c. to the vertical amplifier, the approximately sine wave nature of the line voltage has been verified, and the trace made to stand still. For low frequencies such as 60 cycles, since less than the full sweep voltage may be taken off, due to gain control position, the spot is off the screen along the horizontal for a considerable part of the time, hence there will be flicker, already discussed, but not a source of worry, as it

III. OPERATING TECHNIQUE

WHILE the 913 tube will greatly increase the number of uses of cathode-ray oscilloscopes, the creation of the proper spot size, position, focus and brilliance, as well as the development of patterns for observation, and the significance of designs and quantities are exactly the same for the small tube as for larger tubes.

There are highly satisfactory other means of accomplishing many measurements within the capabilities of the cathode-ray tube, and it is not necessary to say that the cathode-ray tube supplants or even substitutes for these other methods. If d.c. voltages are to be compared,

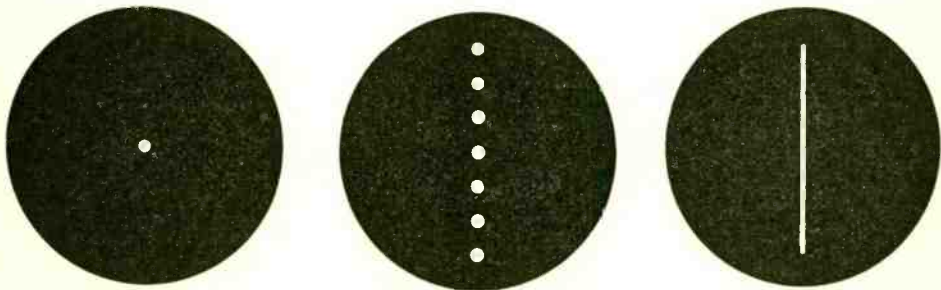

FIG. 7

The spot as shown at A exists by virtue of the operation of the electron gun, without any input to either deflecting plate. When the input to the vertical plate is made, and the frequency is low enough, the spot is made to travel up and down, and appears as a series of dots, as at B, but not as distinctly as shown. When the frequency is high enough the series of dots is developed into a line as at C.

does not injure the examination nor prevent photography. Naturally, for photography to be practical the image must stand still, and the distinction between fixed position and flicker should be borne in mind.

With the oscilloscope set up as described, the instrument is equipped for service work and experimenting, with a range great enough to permit viewing waves in the audio spectrum and to low standard broadcast frequencies, hence including intermediate frequencies. The limitation is a practical one, in that the neon tube oscillates perhaps to 100 kc, and for examination of 500 kc applied to the vertical axis there would then be five cycles. For 600 kc there would be six cycles, etc., so it is a matter of how many cycles can be considered not too many on the screen. For comparison of frequencies higher than, say, 1,000 kc for the present instrument an external sweep oscillator would have to be connected to the H input, and meet the requirements imposed for sweep oscillators generally. These requirements have been stated in detail and also summarized.

it can be done practically at no current drain on the measured circuit by the cathode-ray tube, but the same purpose is accomplishable with a vacuum tube voltmeter of the proper range and sensitivity. A.c. and d.c. voltages may be measured by the tube voltmeter or other devices along conventional lines, in general with closer accuracy than by using the cathode-ray tube. Also, frequency measurements are in general better conducted by use of the beat phenomenon, also with far higher accuracy. Even percentage modulation may be as closely determined by other means, say, using a peak type tube voltmeter.

IN A CLASS BY ITSELF

But there are purposes and uses that the cathode-ray tube serves that are beyond the scope of other instruments, and while these purposes in general require extra equipment, nevertheless an understanding of the functioning of the oscilloscope, and the meaning of the

simplest patterns it produces, are prerequisite to a proper understanding and use of the instrument for the more extensive and almost exclusive results that it produces.

Magnitudes of d.c. voltages, also magnitudes and frequencies of a.c. voltages, may be determined preferably by conventional means, but those methods of disclosure fall short of permitting an inspection of the shape of a wave, for instance, whether it is a sine wave, and if not, how much, and in what manner, does it depart.

Considering, then, only a.c. inputs, we shall take up single phase and polyphase patterns, with and without modulation, and if a wave is never intended to have any modulation, as for instance the wave of the a.c. line current of 60 cycles, we shall consider it simply as a carrier that is unmodulated.

First we create the dot due to the beam of electrons from the electron gun, or basic operating foundation of the tube. No input is made to the vertical or horizontal deflecting plates. Then we introduce first one, then, the other of

Unless the controls are properly set we may see a picture far different from that of the wave we had expected to analyze. For instance, we might view some parallel lines, or odd short lines at various fixed angles, or a straight line, or actually see nothing. It is quite possible to see nothing when all controls are properly set save only the intensity control.

LIKE SNAPPING PHOTO

If we use the 60-cycle line frequency for V input, knowing that we should see a good approximation of a sine wave, if we make the proper adjustments for intensity and focus, and limit the boundaries of the pattern to well within the screen, and preferably if we adjust the gain so that the amplitude of one dimension is equal to that of the other, we should be able to stop the image to a single wave, using the range switch at maximum capacity setting (.1 mfd.).

Immediately we must know the difference between patterns representing one wave and more than one wave, otherwise we would scarce-

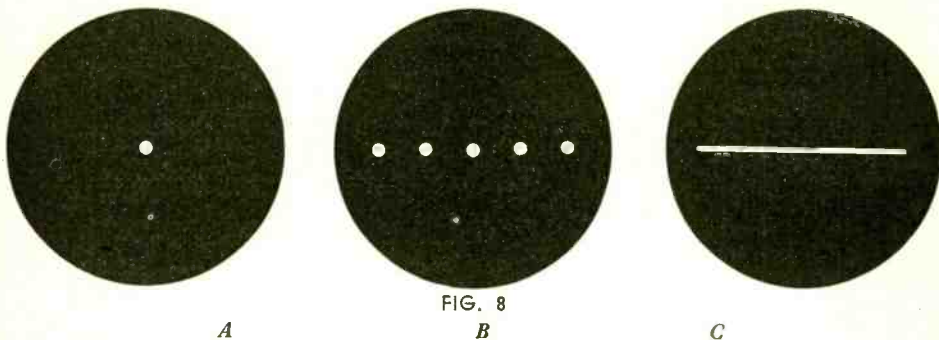

FIG. 8

The same principle applied to the vertical deflection governs the horizontal deflection. In this case the vertical voltage has been removed, and where there was no horizontal voltage, as in Fig. 7, one is applied now, with dot at A for the start, series of dots at B for low sweep frequencies, and finally a line at C for sweep frequencies higher than 10.

the two voltages, the sweep for the horizontal purpose and the unknown for the vertical purpose, and by proper adjustments we bring a pattern on the screen that stands still, perhaps occasionally flickers a little, without movement from a fixed position for the pattern itself.

CONTROLS MUST BE RIGHT

The dot we see as a dot. When the sweep frequency is introduced, if it is low enough in frequency, there will be a series of dots, but due to persistence of vision there will not be a clear dot at all times, but there will be the appearance of a elongated dot, nevertheless the separateness of what we understand are dots is clearly evident. When we increase the frequency sufficiently the semblance of dots disappears and we have a line, much the same as if d.c. instead of a.c. had been used.

In the direction at right angles we repeat the process, except that we need not shut off the sweep circuit to restore the stationary dot, but simply introduce the unknown into the vertically deflecting circuit.

ly know when we had one wave. What is really meant by the loose phrase *one wave* is that the trace is the same as that for a single cycle of the wave under analysis. Sixty such cycles occur a second, for the case of the 60-cycle a.c. line current considered, so what we have done, in a sense, has been to take a picture of the wave in one-sixtieth of a second, whereupon our imaginary negative would show one cycle.

If we look at the representation of the first wave form in the illustration we will note that it starts at a given level, travels through the positive and negative alternations, and ends on the same level from which it started.

Any continuation would be into the succeeding cycle. So we have one cycle and may examine it, photograph it or trace it on translucent paper or cloth. It we want it to be wider we may increase the input sweep voltage, using the H gain control, or narrower, decrease the sweep input voltage. Likewise we may regulate the height, by actuating the V gain control. Still we shall have one cycle, and only one cycle.

(Continued on following page)

(Continued from preceding page)

If the vertical wave changes in an up and down direction so as to permit only one cycle to be seen on the viewing screen, then the spot must be moving at the same rate along the horizontal axis. The ratio is then 1 to 1.

Before making an analysis so we can tell the ratios of frequencies, and which term applies to which frequency, we should decrease the

for instance 1 to 1, 1 to 2, 2 to 5, etc., and the first-mentioned number will represent the vertical frequency's least common integral denominator, the second number the horizontal frequency's least common integral denominator. By counting the peaks along only one of the two rows we found just three. How may we find out by inspection what the other number is, though we know the answer is going to be

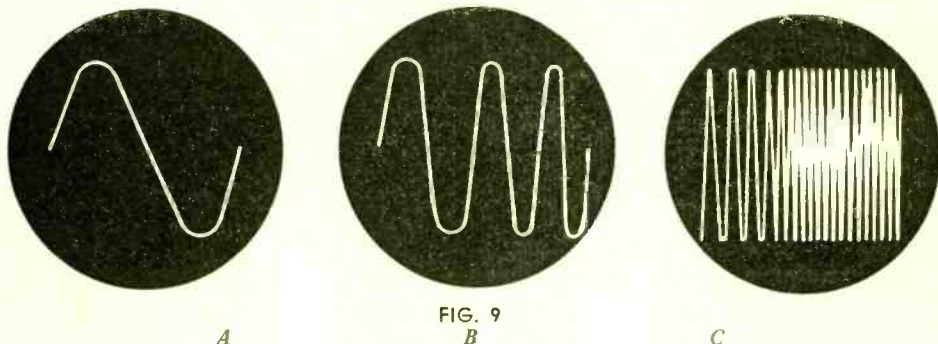

FIG. 9

By combining the two right-angle movements of the spot delineated in the two preceding illustrations we finally develop our first pattern. At A one cycle is shown on the screen and the sweep frequency is equal to the frequency of the voltage input to the vertical posts, hence ratio is 1:1. The pattern at B represents three cycles of the vertical wave, so the sweep frequency is one-third the other, or ratio 3:1. Also, B shows what one may normally expect along the lines of non-linearity. The waves may be closer at left than at right (reversing the illustrated example) depending on the tube position. When too many vertical waves for easy counting are present the pattern is as at C.

sweep frequency so that the sweep cycles per second are fewer than those of the vertical wave, whereupon the horizontal wave or sweep may be, say, half that of the other, and we see two full vertical waves, because of the V frequency being twice that of the sweep, the H wave takes twice as long to travel the distance, and there are two V waves to one H wave.

The decrease in the sweep frequency is illustrated in Fig. 9B as the development of a greater number of V cycles, starting with one, proceeding to three and then to a number too great to count readily. It can be seen that three cycles will do nicely. Also the absence of complete linearity is apparent, the cycles to the right being progressively closer together. This represents sweep voltage change not being uniform with time. The second cycle is completed more quickly than the first, the third more quickly than the second.

If we consider the three-cycle pattern of Fig. 9B, and count the number of peaks found either below or above the horizontal axis, we find that there are three peaks. The lower row will be selected, just so that a definite basis will exist, and also so that we shall remember not to double up on the peaks by counting those on top and those on bottom. They represent the same peak voltage, in one instance the maximum positive, in the other instance the maximum negative. Also, peaks occur twice as often as cycles for the same reason, i.e., there are two alternations to a cycle.

The ratios between the two frequencies may be taken as the comparison of whole numbers.

1? We shall say for the present that the second number is one because there are no intersections.

COINCIDING THE WAVES

If we consider the oscilloscope as a transparent cylinder on which an image can be projected, we can realize that two images could be seen, one due to the outside front, the other to the inside rear projection. But we could arrange our viewing, or the pattern position, to make both front and back waves coincide, and so far we have done this, hence do not create what looks like the third dimension.

If we do not create such coincidence, we might get a pattern something like 10A, which represents a phase displacement, for front and back waves are seen separately though at seemingly the same time. We do not desire this separation at present, so we adjust sweep frequency, and sometimes also gain control, to establish the pattern that distinctly represents the back wave covered by the front wave. The sense of what is intended is best gleaned from the illustration, and we may get the idea of a pair of scissors with open blades for the out-of-phase case, and closed blades for the superimposed wave case.

Now we shall find out the frequency ratios for two patterns of in-phase voltages.

Immediately we notice something we did not have in the case of any ratio of $n:1$, where n is a whole number. That is the introduction of the intersection. If you draw an x the inter-

section is where the lines cross. The count is made along the horizontal axis. In Fig 10B, starting from the bottom, as if with a ruling edge, move upward, and at center the imaginary line of real intersection is met, the only such line. Hence the number of intersections is one. The ratio of frequencies follows the simple formula, $V: H+1$, where V is the number of peaks of the vertical wave and H is the number of intersectional planes. So we had three V peaks and one intersectional plane and the ratio is $V_1: H_2$, written 3:2 if V is understood to apply to the first term and H to the second. We know which is which, hence cannot confuse V and H waves, from the way the os-

enough, the representation looks like a band of light.

We come now to phase displacements. These patterns are known as Lissajous' figures. Two alternating currents are put into the cathode-ray tube, and for the simplest case their frequencies are the same, or the ratio is 1:1, while the cases of higher ratios represent less simplicity, very high ratios considerable complexity.

It has been said that some facts must be memorized, so that finally the oscilloscope may be used rapidly, and the first serious encounter with this requirement relates to the phase relationships. Also, it is in the detecting of phases that the oscilloscope performs one of its im-

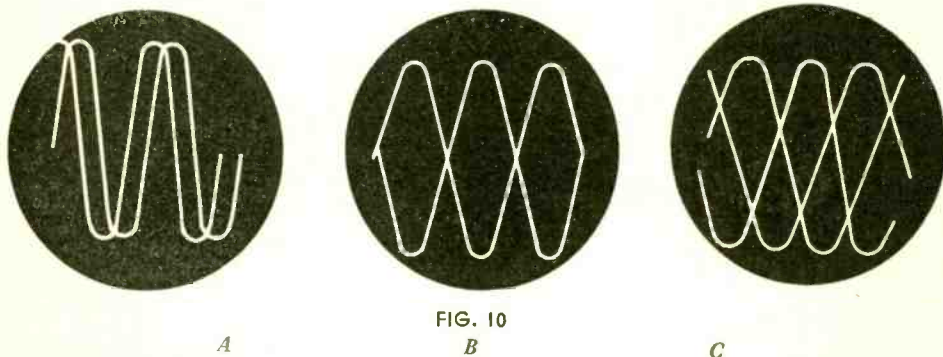

FIG. 10

The ratio of frequencies is not solved for A, but the two waves are not coincided, which should be done by fine sweep adjustment. Normally the back wave, or return wave, is a fainter line than the other, hence its presence is easily noted. The ratio of frequencies is 3:2 in B. Note that the waves are terminated at the ends. At C this is not so, nor are the starts and finishes made on the same plane. A and C are patterns to avoid for the present. Superimpose the waves and also terminate them by closing.

cilloscope was built, and the identities of output posts or switch positions.

Now take the next pattern. This one is difficult to analyze on the basis of information thus far imparted. There are four peaks on the bottom now, three on the top, whereas we were counting on equal number in both rows. We notice that the trace does not close at the ends (left and right), but it is handier to terminate them exactly at first. Besides the phase difficulty, shown by open ends, i.e., starting and finishing out of step, the wave is also not quite symmetrical. The figure may be considered as something to avoid for the present because we are concentrating on closed-end patterns, and avoiding phase shifts. Also, all patterns should start and end on the same horizontal plane.

LISSAJOUS' FIGURES

The simple direction already given for determining frequency ratios, using a linear or substantially linear horizontal sweep, and any a.c. input wave, will enable ratio determination for coincided waves.

If the sweep frequency is high compared to the vertical frequency there will be so many intersections that they look like crowded fine lines, and finally if the sweep frequency is high

portant functions, and puts other instruments in the background, just as it does in viewing of simple wave form of in-phase voltages.

In Fig. 11 are shown, left to right, figures that may be imagined as five spokes of a wheel, the hub farther up and unseen, and the segments of the spokes examined. In two instances the spokes are plain lines, in three they are ellipses, for we assume the spokes have enough elasticity to permit the configurations we require.

These slants should be memorized, because they are basic, also because they occur again and again in more complex patterns. If we take the two plain lines, and transpose A to E, we have a V, and if we imagine we are reading a book we put the E stroke on the left-hand page and the A stroke on the right-hand page, and we memorize the fact that we start at top left and wind up at bottom right as we do when reading a page, and find the slant is there for 0 phase displacement. On the right-hand page we draw the other V branch, bottom left to top right, and have the slant for 180 degrees out of phase. These plain lines apply even though the voltages are both a.c.

But for other phases the spreading effect takes place, and the slant is less for 45 degrees than for 0 degrees, while for 90 degrees the pattern's

(Continued on following page)

(Continued from preceding page)

axis is straight up and down, and for 135 degrees the slant is as for 45 degrees, out in the opposite direction. So we can carry the book analogy farther, and say the left-hand plain-line V stroke is 0 degrees, the perpendicular at center is 90 degrees, but elliptical, that slant of 45 degrees is the algebraic difference between 0 and 90 degrees, and that 135 degrees is represented by an ellipse on the right-hand page, equal but opposite in pitch to the 45-degree loop on the other page, and 180 degrees is again a plain line, the opposite counterpart to the 0 degree phase displacement.

When the ratio is 2 to 1, the looped patterns, G, H and I, have the intersection, add one, and you know 2 is the answer. The other frequency term is 1 because there is what may be termed one peak on a single row, say, the lower row.

V.
SERVICE APPLICATIONS

THOSE applications of the cathode-ray oscilloscope which practically anybody can understand from a single reading of an explanation may strike some as contributing very little to the measurements that they already can make with instruments they have. The first impression therefore may be that an oscilloscope is less than necessary, the time for obtaining or constructing one may be indefinitely postponed, and no further study of its uses is warranted.

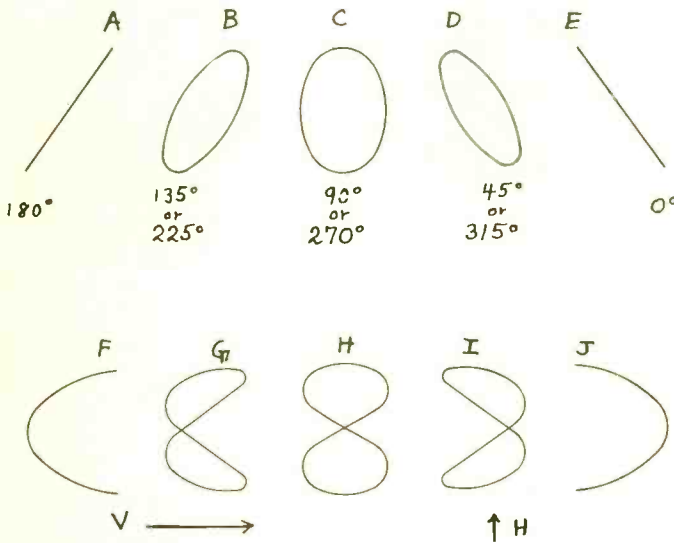

FIG. 11
The phase relationship, for a 1:1 frequency ratio, with sine wave input to both sets of deflecting plates, are shown immediately to the left, at A, B, C, D and E.

The phase relationships, also for double use of sine waves, but for a frequency ratio of 2:1, are shown immediately to the left, at F, G, H, I and J. In both instances angles noted apply to the vertical column, i.e., include upper and lower patterns.

However, there is no intersection for the 0 and 180 degree examples, and the patterns have to be memorized as to the direction in which the two plain lines bend. Both bend in the direction of going off the page, to resume the book analogy.

The degrees have been cited from 0 to 180, but the same pattern appears for 360— ϕ , where ϕ represents the stated degrees in the text. The diagram is marked for both values where any figure has two values, and these are three each of the two pairs of five represented.

That is as far as we can go at present, for lack of space, so that we have ascertained:

1. How to determine frequency ratios.
2. How to identify phases for frequency ratios of 1 to 1 and 2 to 1.

We have taken up only a few simple applications, requiring no external apparatus. We shall be able presently to examine an unmodulated wave and compare it with modulation present, for modulation distortion, without detection. But when we want to note the response curve of an r. f. or i. f. amplifier we shall need frequency modulation, also detection.

As added argument it might be thought that, for the elementary applications, viewing a wave form is about all that can be accomplished beyond the capabilities of instruments at hand, and what is the real necessity of looking at the wave form, anyway? It is derived from a tuned circuit in common practice and may be taken as sinusoidal for that reason.

OSCILLOSCOPE CALLED VITAL

However, when it is realized that there are a great many services, one might say feats, that the oscilloscope can perform beyond the field of meters generally, it is only necessary to ascertain whether these extraordinary services provide anything of value to the service man and experimenter. Also, the oscilloscope does provide measurement means, not beyond those of other instruments in many cases, but permit making measurements that other instruments make, say, a tube voltmeter. And if the service man possesses an oscilloscope, then he possesses

the basis of a tube voltmeter, and few are the service men that have tube voltmeters. Still, a tube voltmeter is an instrument absolutely necessary to proper service work, because enabling measurements of alternating currents of practically any frequency, also direct current voltages, all without loading the circuit being measured, hence not changing the unknown voltage when attempting to ascertain its value. It is therefore too true that service men do not possess all the instruments that best serve their daily work, and if they do not possess a cathode-ray oscilloscope, they simply lack another vital instrument.

What has been presented thus far is the elementary basis of the oscilloscope, its easiest, readiest and simplest use, applicable restricted to unmodulated waves. When all uses are con-

preferably synchronized with the audio signal, applied to the H posts. The patterns, before and after passing through the amplifier under test, are compared, so distortion is easily and accurately determined. Thus we have two different methods:

1. Application of the r.f. to the vertical plates, with output of modulator used as sweep, developing *trapezoidal* patterns, so called because they look like truncated cones in many of their forms.

2. Application of the r.f. to the vertical plates again, with linear oscillator used as sweep, synchronized with the modulator, developing *modulated-envelope* patterns.

These and other uses of the oscilloscope will be detailed in succeeding issues, including use of a "wobbler," e.g., frequency modulator.

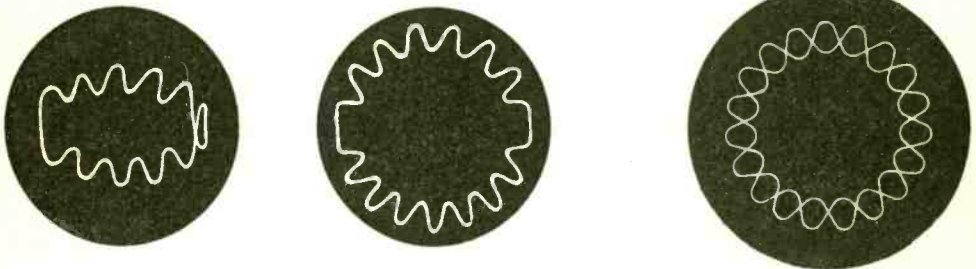

FIG. 12

A

B

C

When the phases are unequal and the frequency ratio is 1:1 both the phase relationship and the frequency ratio may be determined. The phase is determined by the general slant or incline of the ellipse, and the ratio by counting the number of peaks, including virtual peaks at sides, for vertical, and the number of intersections. The sweep term follows the $n+1$ rule, where n is the number of intersections. Illustrated are A = 10:1; B = 15:1; C = 19:2

sidered, the applications are so numerous that they probably never have been all brought together in any single volume.

The wobbler offers an extraordinary advantage, in that the amplifier response characteristic for a selected band width may be studied.

WHAT IS AND WILL BE

AVOIDS ERRORS

It is therefore necessary, in the limits of a single article, to state only fundamentals, an understanding of which is necessary as a basis for the wider and more important applications, scarcely broached in the present article.

In this way, and practically only in this way, may the intermediate or other channel be peaked for flat-top without distortion, avoiding large and serious errors of other methods.

The treatment thus far has been:

1. Development of the instrument.
2. Observation of patterns wherein the wave shape of unmodulated waves may be examined, and the ratio of the two frequencies, vertical to horizontal, determined.
3. Introduction of phase displacement, determination of phases and use of phase shift to split up the trace.

Therefore we have taken up some single-phase figures; also poly-phase patterns, known as Lissajous' figures; and the next step is to consider patterns of a modulated wave.

This next step requires either that the modulator output voltage be introduced as H sweep for V input of r.f., or that the r.f. be applied again to the V posts, linear sweep

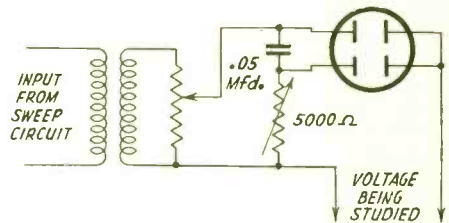

FIG. 13

If it is desired to displace phases by introducing apparatus at the input deflecting plates, it may be done by using this circuit.

An Approach to Television

By Understanding the Service Oscilloscope

By J. E. Anderson

MORE and more service men are providing themselves with cathode-ray tubes for making diagnostic tests on radio receivers. The number of useful and interesting tests that can be made with one of these devices is limited only by the ingenuity of the service man. There will be still more as soon as television receivers become widely distributed, for there is no doubt that future television receivers will be based on the cathode-ray tube. Those who realize the possibilities of the cathode-ray tube in this field are now experimenting with it in order to be prepared. Already they have television signals with which to work.

The method of using the cathode-ray tube for television reception is somewhat different from that of ordinary service applications. It is not only necessary to provide controls of the cathode ray beam in the horizontal and vertical directions but also a control for varying the intensity according to the video signal. Without a control of the intensity of the beam nothing could be seen on the screen, except an indefinite glow.

EQUI-DISTANT DEFLECTIONS

The two deflection controls must be such that the luminous spot moves equal distances in equal times. That is, they must be linear. If they are not, the image, if one can be brought out, will be distorted in somewhat the same way as the image in a "caricature" mirror. Besides this required linearity, there must be perfect timing. If there is not, the image might move about on the screen, or it might not appear at all.

If the horizontal timing is a little off it might be that a certain light element that should appear at the right of the picture will actually appear at the left. Or if the vertical timing is out a little, it may be that a light line, or stroke, that should appear at the bottom actually appears at the top. If this displacement is fixed, it makes no difference, but if it is due to lack of correct timing it will not be fixed. It will move, and that is one of the troubles.

AMPLIFIER REQUIREMENTS

Linear deflection is provided by charging a condenser at a constant current rate, as through a saturated pentode, and discharging it quickly. The discharge may be either through a neon tube or through a grid-controlled gaseous tube. The advantage of the grid-controlled tube over the neon tube is that the grid provides a means for discharging at the right instant, that is, for synchronizing. The synchronizing pulse, which is part of the incoming signal, is impressed on the grid of the discharge tube. The neon tube has the advantage of lower cost.

Both deflection control voltages must be linear and both preferably should be timed. One of them must be. For brief glimpses of the image, the timing may be done manually quite independently of the incoming timing pulses. If the saturated pentode is used for obtaining the linearity of the deflecting voltages, the simplest way of controlling the rate of charge, and hence the timing, is to control the grid voltage of the pentode. For very fine control of the timing, a small rheostat could be inserted in the plate circuit.

If the deflection voltages are linear and suitable for the reception of television signals, they are also suitable for taking characteristic curves. Only one would be needed, the horizontal. The phenomenon studied must supply the vertical deflection voltage.

Suppose now that a cathode-ray tube has been provided with the proper linear deflection voltages for the two sets of plates, as well as a means for taking advantage of the timing pulses. What shall be done to make the television images visible? In the first place, a simple receiver must be provided. This must be stable as to output, and the detected and amplified signal should be of the very best quality. It should be nearly independent of frequency up to about 200,000 cycles per second. A sound receiver of the highest quality need not have a range greater than about 10,000 cycles per second. Hence the requirements for good television signals are at least 20 times more severe.

THE SELECTIVITY PROBLEM

It is clear that the television radio receiver cannot be very selective. Yet some selectivity is required, for otherwise noise transients would cause splashes on the image.

The video signal output from this receiver must be stepped up so that the voltage amplitude is from 20 to 60 volts, depending on which tube is used for reconstructing the image and on what voltages are used on its elements. This signal is impressed on the control grid of the cathode-ray tube, and is superposed on a suitable bias. This bias should be selected so that the operating point is at the steepest point of the grid-voltage, spot-intensity characteristic, or so that the characteristic is substantially linear over the operating range. The mean intensity of the spot on the screen, and hence the apparent mean brilliancy, is determined by the bias. The contrast, which is the most important quality, is determined by the amplitude of the video signal as impressed on the control grid of the cathode ray tube. This can be varied, of course, by any of the standard volume controls.

Volume Control Troubles

They are Foremost, Sometimes Baffling

By Jack Goldstein

VOLUME control troubles are so frequent that they occupy a position up near the top, if not at the very top, of servicing problems. The reason is that so long as high-resistance volume controls must be used, and no method has been found to develop economical wire-wound types of high resistance, the carbon types or something like them must prevail, and will wear out.

If the volume control is defective it may be practically open, or may change its resistance value as the receiver is operated, hour for hour, or may even be substantially shorted. At some place, after a time, the control will show, or rather reveal aurally, signs of wear, and as this spot is the weakest it will be the first to give, and an open control results.

THE LEAD-PENCIL MAKESHIFT

Some service men take an ordinary lead pencil and draw a line, on the resistance base, so that what was formerly an open becomes conductive once more, but this is only a makeshift and should be done as an emergency operation only. First, the repair will not last, and there is no sense calling a job finished when it will surely invite early recurrence of trouble. Second, the volume control likely has a taper, seriously changed, and erratically so, by the pencil-line resistance restoration. Thus, the resistance total may be anything, hence wrong, and the service man who makes the pencil type of repair may not be of the sort who stops long enough to determine what resistance value he has produced. For a control that should have 50,000 ohms total he may have 1 meg. alone where he has drawn the line, so to speak.

Here is my motto on this type of repair: "Pencil lines never stay put."

Of course the best procedure is to replace the defective volume control. In so doing, either an original replacement model should be used, or a duplicate replacement, identified as correct for the chassis in the catalogue of a reputable manufacturer of volume controls.

If a taper is required, then of course the same taper will be duplicated, and this is important, because for some uses the control has great resistance change over a small angular displacement of the control knob, for other uses the change is more gradual, or may be in the opposite direction.

MUST BE RIGHT TWO WAYS

The control therefore is right only when the resistance changes with correct increment and

in the same direction. If the increment were right but the direction wrong, what would be the harm? Well, the harm would be that if two volume controls are on the set, or a volume control and a tone control, one would have to remember which way to turn which, as they would operate to the same volume effect in opposite directions of rotation.

You often find in r.f. sets and supers a volume control that both cuts down the input to the first tube and increases the negative bias at the same time, as detailed in the small illustration. Usually the value is from 10,000 ohms to 20,000 ohms maximum. But not any

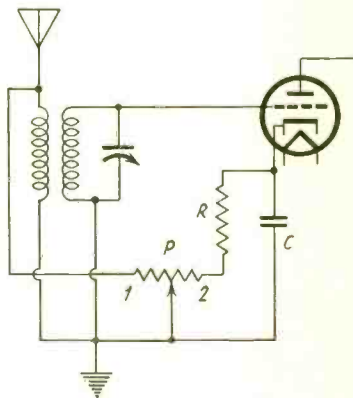

Example of a combination antenna-input and cathode-bias control, as found in many small sets, both r.f. and supers. If r.f. squealing is encountered, use of a higher capacity from cathode to ground often produces complete cure. The capacity may be .1 mfd. ordinarily, and would be increased to .25 or .5 mfd. This is C in the diagram. P is the volume control, usually 10,000 to 20,000 ohms, moved from 2 to 1 to increase bias and decrease r.f. input, thus decrease volume.

and every type of control of the same resistance value may be used.

GROUNDING THE CASE

The manufacturer of the set selected the taper so that the control would work fairly uniformly over its range, the e.g., quantity of sound would change in about equal steps of db for equal angular displacement, approximately, of course. If a straight resistance change exists in the control—the so-called linear curve—then a very abrupt change of volume
(Continued on following page)

(Continued from preceding page)

will take place at some particular setting, until reaching which there would be little change of volume.

There are various types of tapers, depending on the circuit in which they are used, and the manufacturers of controls list them and give them numerical and alphabetical designations, and even recommend certain tapers for replacement in specified receivers. These manufacturers have gone to great cost and pains to allocate their controls to the replacement purposes they can well serve, and the service man should by all means possess these booklets and become familiar with the really important information that they contain, for the controls themselves are readily obtained from one's supply house, e.g., Allied Radio, Chicago; Wholesale Radio Service Co., New York, Atlanta, etc.

When a control is used in a circuit that has

stored. This goes for any circuit, with or without a.v.c., and whether the control is associated directly or indirectly with a.v.c.

Not only oscillation troubles have been cured by this simple grounding expedient, but also hum has been obliterated, although some incipient or more violent oscillation naturally would be associated with hum.

The control with a.c. switch attached has proved handy indeed, and an extra knob and semi-control therefore eliminated from the panel, but when one considers that the a.c. line is thereby brought near some element, e.g., volume control, that may be at a high radio-frequency or particularly audio-frequency potential, then the reason for hum pickup becomes more obvious, and the need for grounding the frame more apparent. A new-style control, with metal frame as part of the structure, so grounding of frame is practical, often stays the hand

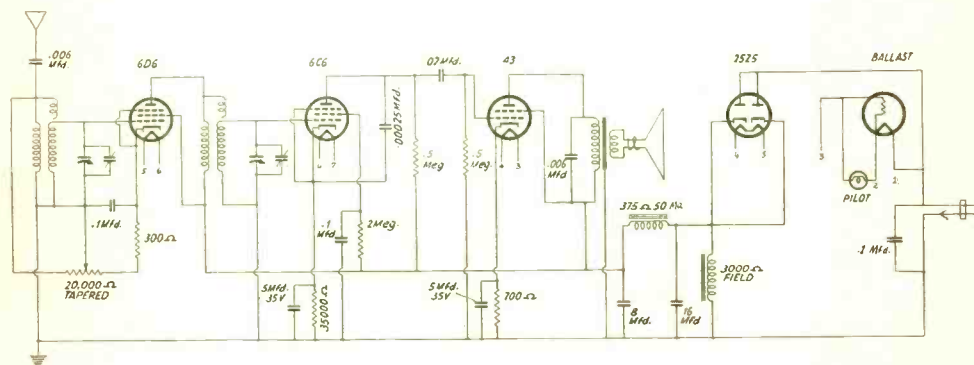

Example of a small a.c.-d.c. receiver, using the antenna-input, cathode-bias type of volume control. This type of control loads the antenna circuit very considerably, as for maximum volume the biasing resistor and bypass capacity in parallel with it are across the antenna winding, while at minimum volume setting the primary is shorted.

automatic volume control, and the variable resistor is related to the a.v.c. circuit in any way, the metal case of the control should be grounded to the chassis. I will go so far as to say this should be done in any volume control repair job on an a.v.c. circuit, whether the set manufacturer originally took that precaution or not. The reason is that I have found ever so many instances where high degrees of oscillation obtained at intermediate-frequency and even radio-frequency levels, cured by grounding the frame of the control.

A.C. SWITCH ATTACHED

Also, some sets using a.v.c., where the control in any way affects the a.v.c. circuit, even only to taking off some audio voltages, were made before control manufacturers generally made controls with frames permitting this safety from oscillation and other troubles.

Even if oscillation trouble is absent, if the control works poorly, try grounding the frame to the chassis in any instance, and see whether the full reliability of the control is not re-

of hum, where the old type of control, no shielding practical, yet with a.c. switch attached, would prove a baffling problem.

WIRE-WOUND CONTROLS

It has been said that the carbon and similar types of controls must be expected to give trouble finally, although some of them last a deucedly long while, so long that service men eager to earn a better living might hope at times that the control manufacturers did not produce quite such rugged products. It need not be inferred that the wire-wound control, used in circuits where relatively low resistance is sufficient, hence where current in some appreciable quantity is passed, never gives offense.

These controls become scratchy and jumpy, too, because the slider finally wears out some part of the wire winding ahead of the other parts. To reduce or eliminate scratch some brand of lubricant like Russian mineral oil, sold in drug stores under various trade names, may be applied as a temporary help. The freedom from scratch remains only so long as sufficient

An Audio Test Oscillator

Twin Tube Used with Coil Switch

By M. N. Beitman

A VERY simple audio oscillator can be easily constructed using but a single commercially available coil and condenser for each frequency produced. The model here described uses a single type 6A6 tube, but any other dual type tube or two separate triode tubes may be used instead.

Upon examining the circuit illustrated you will notice that the two triode sections of the 6A6 tube are coupled. The grid G_1 of the first section is connected to the plate P_2 of the second section, and the second section grid G_2 is connected to the plate P_1 of the first section. Any slight unbalance in the circuit such as applying the plate voltage will cause an excitation of grid G_2 .

If we assume that this initial excitation caused the grid potential to advance in the positive direction, the plate current of P_2 will be greater. This current increase will in turn cause a larger voltage drop across the 75,000-ohm plate resistor and will apply a greater negative bias on grid G_1 .

SWITCH ON DIFFERENT TONES

Proceeding with our analysis we see that this action in turn will reduce the plate P_1 current. The result from this will be the reduction of potential on grid G_2 , and the action explained will be repeated but in the inverse direction. The number of times per second this action will take place will depend directly on the natural period of LC combination. At audio frequencies other factors in the circuit and the tube's parameter and age will have but little effect.

It is evident that this simple arrangement, using relatively few inexpensive parts, will make an excellently adaptable audio service oscillator. The LC combination may be made from different sizes of inductance and capacity for obtaining any desirable audio frequencies.

In the circuit a switch is shown for this purpose. Usually only the essential frequencies are needed. The selection of the inductance and capacity combination for the different frequencies is explained in detail below.

The natural frequency of a parallel LC circuit for all practical purposes may be considered as

$$f = \frac{1}{6.28\sqrt{LC}}$$

The frequency f varies inversely as the square root of the product of the inductance and capacity. The table gives suitable values for L and C for commonly-used test audio frequencies.

NEED FOR GOOD FILTER

The audio oscillator uses a 100,000-ohm potentiometer for attenuation of the output, thereby permitting the control of the output level from zero to maximum. The setting of the 50,000-ohm potentiometer will vary the output somewhat and will determine the obtainable waveform.

The power for operation is obtained from common power supply circuit using a type 80 tube for the rectifier. This supply operates on

LIST OF PARTS

Coils

One power transformer, primary 110 volts; h.v. 350-350 @ 40 m.a.; 5 v. @ 2 amp. and 6.3 v. @ 1 or more amp.

Choke coil, 30 henries.

See text for L_1 , L_2 and L_3 .

Other Requirements

A.C. cord and plug.

S.P.S.T. toggle switch.

Sockets: one 7-medium prong, one 4-prong.

Tubes: one type 6A6, and one type 80 (Sylvania).

Chassis base and hardware.

Roll of hook-up wire.

Output jacks, one red and one black.

Two knobs.

Panel and box.

Condensers

One 10 mfd., 35-volt electrolytic.

One .05 mfd., 400-volt paper.

One .1 mfd., 400-volt paper.

One dual 8 mfd., 550-volt electrolytic.

(All condensers products of Cornell-Dubilier.)

See text for C_1 , C_2 and C_3 .

Resistors

One 750-ohm, 1 watt.

Two 75,000-ohm, 1 watt.

One 100,000-ohm potentiometer with line switch attached.

One 500,000-ohm potentiometer.

(All resistors products of International Resistance Company.)

110 volts a.c. The filter is ample for the needs of the circuit and prevents the appearance of a 120-cycle note present at the rectifier, and the locking-in of the 120-cycle harmonics with the output frequency.

The unit is very well adaptable for all-around audio testing, especially testing and comparing public address amplifiers.

Frequency Cycles per second	Inductance Millihenries	Capacity Microfarads
400	160	1.
800	80	.5
1,250	40	.4
2,000	30	.2+.01
5,000	10	.1
10,000	10	.025

Twin 6A6 tube and rectifier, with circuit for production of audio frequencies, one tone for each tuned circuit switched in. Three tones are represented, since a three-position switch is shown. A table in the text gives constants from which the three may be selected, or six different frequencies may be used, as the table indicates, using a six-position switch.

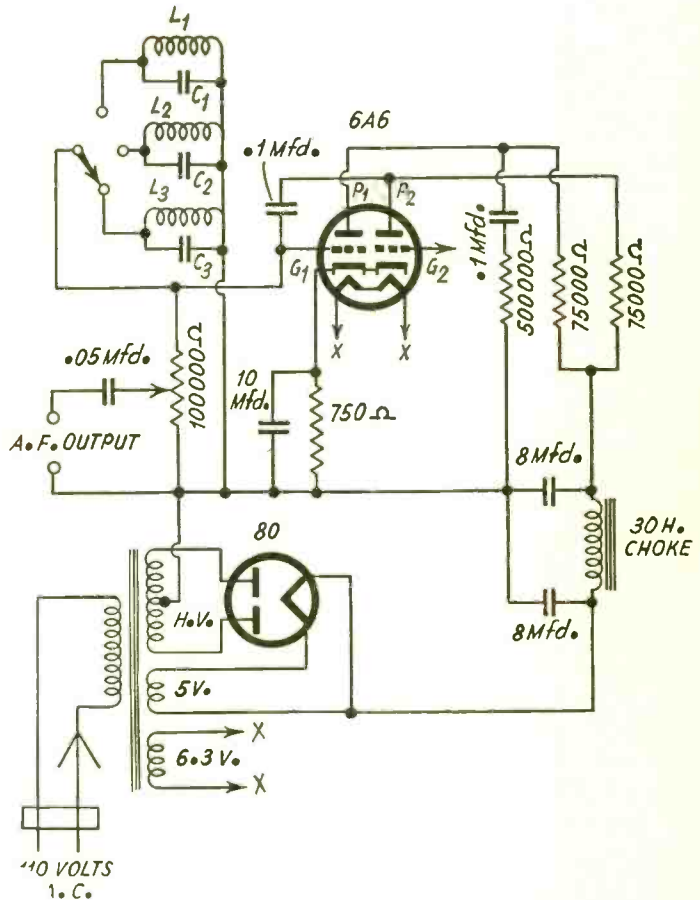

Wholesale Radio Orders Big Rerun on Catalogue

The announcement by Wholesale Radio Service Co., Inc., that the 1937 catalog was ready for distribution brought so great a response that it has been necessary to increase the mailing staff and order a second run of catalogues from the printers.

The "Blue Ribbon Catalog" is the most comprehensive ever issued by Wholesale. It has more than 150 pages, contains more than 2,500 illustrations, and lists, in all, about 50,000 items. The cover is in blue, and the catalog itself in partly rotogravure and partly letter

press printed. "That an immense amount of time, thought and money went into its preparation is very evident," says an announcement, "and a perusal of the prices quoted for various radio items is conclusive evidence of the ability of so large a purchaser as Wholesale to receive every advantage of quantity discounts, which are passed on to the purchaser."

Copies of the catalog are distributed by Wholesale Radio Service Co., Inc., 100 Sixth Avenue, New York City. There are branches in other cities.

A C.W. Transmitter Two-Tube Rig with Beam Oscillator

By **Harvey E. Sampson**

President, Harvey Radio Co. New York

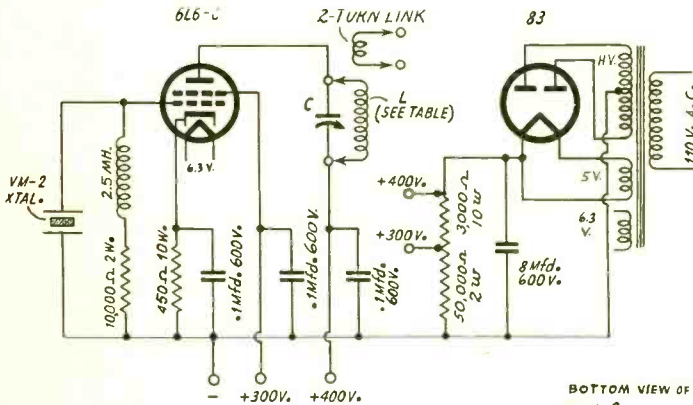

COIL TABLE (L)
FORM = 2 1/2" OUTSIDE DIAMETER
WIRE = No. 16 OCC IN ALL CASES

Meters	Turns	C(Mmfd.)
150	46 CLOSE WOUND	100
80	23 SPACED ONE WIRE DIAMETER	100
40	16 SPACED ONE WIRE DIAMETER	35
20	8 SPACED ONE WIRE DIAMETER	35

A c.w. transmitter, using crystal and beam tube for oscillation. The key may be put between the 10,000-ohm resistor and minus.

BOTTOM VIEW OF SOCKETS

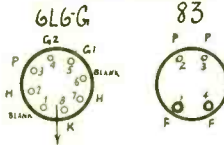

THE 6L6-G beam power tube has been applied successfully to a crystal controlled transmitter in the simple circuit illustrated here. The crystal, VM-2, is put in the grid lead and is shunted by a 2.5 millihenry choke and a 10,000-ohm resistor. A tank circuit, consisting of L and C, is put in the output lead and is tuned to nearly the same frequency as the crystal. A two-turn link winding is coupled loosely to the tank coil for tapping the high frequency energy. This link is connected in the transmission line or the radiating antenna.

The tank circuit is not tuned exactly to the frequency of the crystal because if oscillation is to exist in the circuit, the tank must be inductive. The required detuning, however, is extremely slight. Hence no other selector circuit is needed for picking out the fundamental frequency selectively.

The table associated with the circuit diagram shows the coil design and tuning capacity recommended. It is understood that when a coil is changed the crystal must be changed also. The reason for this is that the circuit will not oscillate unless the tank is highly inductive, as it is, near its parallel resonance frequency. If a harmonic is to be selected, the oscillator must oscillate at the fundamental and the desired harmonic, which exists in the plate current of the tube, is picked off resonantly by means of a tuner not shown. This may have to be done

to get an output at 20 meters, at which no crystal may be available.

No provision is made, on the drawing, for keying or for other modulation of the generated frequency. The key may be placed in
(Continued on following page)

LIST OF PARTS

- One quartz piezo crystal, with holder
- One output coil for tank circuit as described
- One 2.5 millihenry r.f. choke coil
- One power transformer
- One variable condenser
- Three .1 mfd., 600-volt by-pass condensers
- One 8 mfd., 600-volt filter condenser
- One 10,000-ohm, 2 watt resistor
- One 450-ohm bias resistor
- One 3,000-ohm, 10-watt resistor
- One 50,000-ohm, 2-watt resistor
- One four-prong socket
- One octal socket
- One 83 rectifier tube
- One 6L6-G beam power tube
- One small chassis

RIGHT OR WRONG?

PROPOSITIONS

1. The cathode-ray tube's sensitivity is increased as the B voltage applied to Anode No. 2 is increased.
2. The requirements for a condenser in series with a line are the same as those for a condenser in parallel with a line.
3. A short antenna increases the ratio of the noise to the signal because not enough signal is picked up.
4. A parallel resonant circuit is one in which the voltage drop across the coil is the same as that across the condenser.
5. The velocity of radio waves of practically all frequencies is a constant, in a given medium, and is equal to the velocity of light, or about 186,000 miles a second, or 300,000,000 meters a second, and the velocity of electrons in vacuum tubes is less than this.

ANSWERS

1. Wrong. The higher the B voltage, the greater the velocity of the electrons, and the harder it is for the deflecting plates to sway the electrons from their normal path. The sensitivity is inversely proportionate to the B voltage, and the object of a high B voltage is to provide brilliance.
2. Wrong. For a radio-frequency circuit this may on occasion be true, but as a general proposition it is not, because the series condenser is intended to have negligible series impedance, compared to the shunt impedance of the circuit into which it works, while the parallel condenser is intended to have sizeable impedance.
3. Right. The short antenna picks up less noise and less signal but the receiver's internal noises, such as tube "rush," become large compared to the signal, and the noise-to-signal ratio increases.
4. Wrong. While it is true that the voltage drop across the condenser is the same as that across the coil in a parallel resonant circuit, it is also true of the parallel circuit when it is not at resonance, or when the voltage drop across them is zero, hence the voltage drop has no reference to resonance at all. A parallel resonant circuit is one in which the current through the capacity leg is the same as that through the inductive leg, though of opposite phase, hence the net current difference is zero, and voltage drop across both is the same.
5. Right. The electrons in the tube can not attain the velocity of light, otherwise the tube could amplify light.

(Continued from preceding page)

series with the grid leak of the oscillator tube, say between the 10,000-ohm resistor and ground. When the grid circuit is opened, the grid quickly chokes up and oscillation stops. When it is closed, the operating grid potential is restored and the tube begins to oscillate again.

The B supply consists of an 83 full-wave rectifier and a filter consisting only of an 8 mfd., 600-volt by-pass condenser. Two potentiometers connected in series, one of 3,000 ohms and 10-watt rating and the other 50,000 ohms and 2-watt rating, serve as bleeder and voltage divider. The screen of the oscillator is connected to the slider of the lower potentiometer and the plate return to that of the upper. Thus both voltages are variable for optimum adjustment. There is a .1 mfd., 600-volt by-pass condenser from each slider to ground. These facilitate oscillation and confine the generated currents to their proper channels. Another condenser of the same value is connected across the 450-ohm, 10-watt bias resistor for the oscillator tube.

Basis of Tuning Test Is Overall Selectivity

What counts is not the selectivity of each tuned circuit in a receiver, but rather the overall selectivity when every factor has been taken into consideration. It makes little difference as far as selectivity is concerned how it is obtained. The important difference is the cost. Suppose we have two coils each having a selectivity factor of 100. The effect of the two when placed in tuned tandem circuits adjusted accurately to the same frequency is 10,000. If the selectivity is 25 per stage, two stages under optimum conditions will have a selectivity of 625. If there are three similar stages, the total effective selectivity will be 15,600, approximately. The selectivity for the three low-Q circuits is about 60 per cent up over that for the two high-Q circuits. Which can be put in the smaller place and for less cost, the two large, high-Q coils, or the three small, low-Q coils? The small coils.

A Transceiver

By Edgar Lee

Measures Waves It Receives, as Well as Those It Sends—Serves as Detector, Also as Converter

A SERVICE man or an experimenter in radio has need for many different devices—receivers, oscillators, detectors, mixers, frequency comparators, to name a few. Undoubtedly, the best way of building these gadgets is to have one circuit for each function. But what happens when this is attempted? The laboratory or service shop becomes cluttered up with a multitude of gadgets that are seldom used, and usually one can be used at a time. These special devices take up so much room that little is left in which to carry on the work for which the place exists. What is there to do?

One way of avoiding a multitude of gadgets without sacrificing versatility is to build many functions into one gadget. It is remarkable how many things can be done with a single circuit if it is built with flexibility. As an example, consider the circuit herewith. The first tube is a 6A7 set in a nearly standard mixer setting. It can therefore amplify, mix, oscillate and detect. Suppose the oscillator section of the tube is killed, which may be done by opening the anode or the grid lead.

CHANGING PURPOSES

If the bias on the grid (cap) is high, the tube detects fairly well. A following tube can then be used as an audio amplifier. If the bias is less, say about 3 volts, the tube can be used for amplification. The following tube can then be used for additional amplification or for detection. If the RFC coil is kept in the circuit, only radio frequency voltages can be amplified. This does not prevent the use of the circuit for audio amplification, for the grid clip can be slipped off

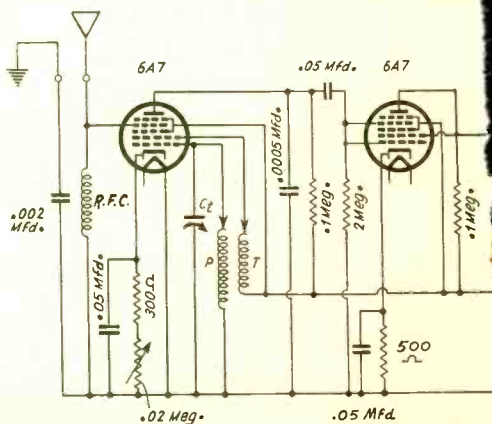
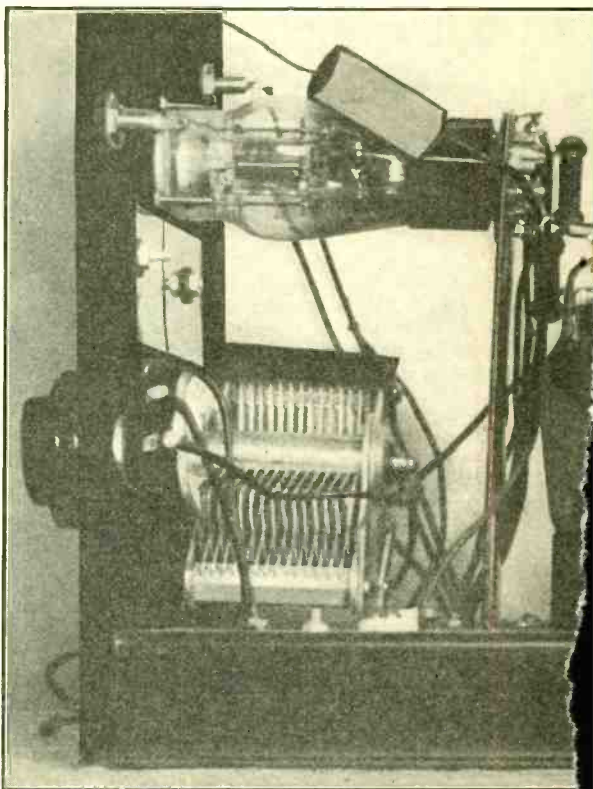

This four-tube circuit is a multi-purpose device which can perform functions of many devices and thus avoids duplication of

Type Test Rig

Wellsworth

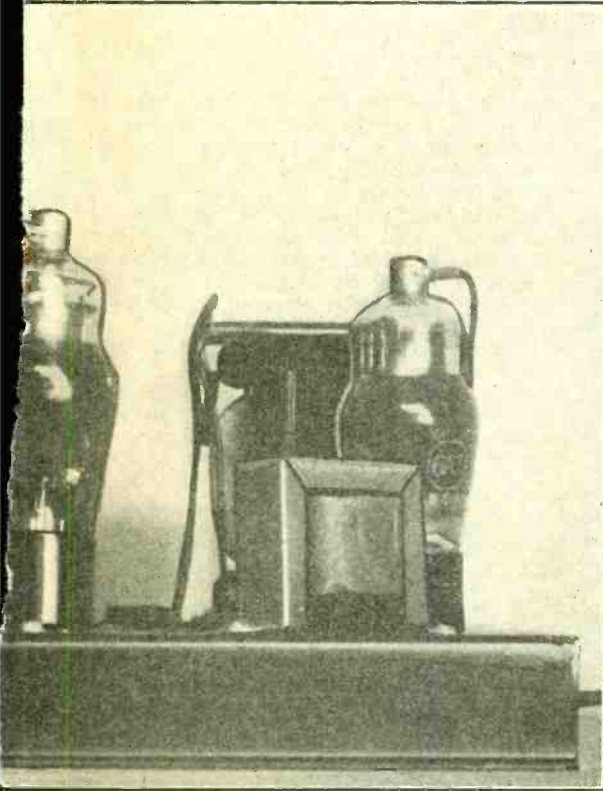

Ray Tube Checks Audio Output of Device, But Also Is Applicable To External Inputs

and another put in its place, to which a high resistance or audio transformer winding is connected. The bias can be varied over a considerable range by means of the 20,000-ohm rheostat in the cathode lead of the first tube. Hence the circuit can be changed easily from an amplifier to a detector, or vice-versa.

Now suppose the grid and anode leads of the oscillator section are both closed. The circuit will oscillate at a frequency determined by the values of the condenser C_1 and the Coil P. The frequency can be varied continuously by means of the variable condenser and in steps by inserting different coils. We have now an oscillator which can be as any other oscillator. The output may be taken through the plate of the tube and may be amplified by the second tube.

USE AS CONVERTER

The first tube is essentially a mixer. The radio frequency signal is connected to the control grid and the oscillator set going. By tuning the oscillator alone various signals can be tuned in, for there is no selectivity in the r-f stage. Such a mixer, of course, is not suitable for permanent broadcast reception but only for temporary use. The experimental nature of the circuit should not be forgotten. The I-F output is amplified by the second tube without selection. Selection might begin after the second tube. The primary of the I-F transformer can be connected directly between the plate and the B supply or it can be connected between ground and the plate if a small stopping condenser is connected in series. To improve the coupling there should be an R-F choke coil in series with the

(Continued on following page)

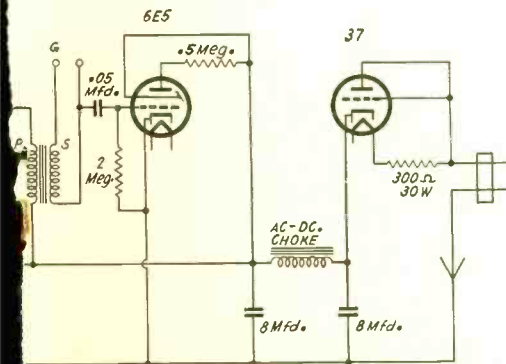

is applied to a large number of tests. It combines the common elements. The photograph shows an elevation.

LIST OF PARTS

One A-C-D-C filter choke.	Two .1-megohm.
One audio transformer.	One .5-megohm.
One radio frequency choke.	Two 2-megohm.
One set of coils for tuned circuit, switch selected type.	One 300-ohm, 30-watt ballast.
One variable condenser.	Four tip jacks.
One (or preferably two) .002 mfd.	Two grid clips.
One .0005 mfd.	Two 7-prong sockets.
Four .05 mfd.	One 6-prong socket.
Two 8 mfd. electrolytics.	One 5-prong socket.
One 300-ohm resistor.	One line cord and plug.
One 500-ohm.	One line switch (may be on rheostat).
One .02-megohm rheostat with knob.	One metal chassis.
	One coil selector switch with knob.
	One dial.
	One front panel, metal.

(Continued from preceding page)

primary of the audio transformer that is now connected directly to the plate of the tube.

As a frequency comparator the circuit is well adapted. A set of headphones is connected in series with the secondary of the audio transformer, one terminal of which is marked G.

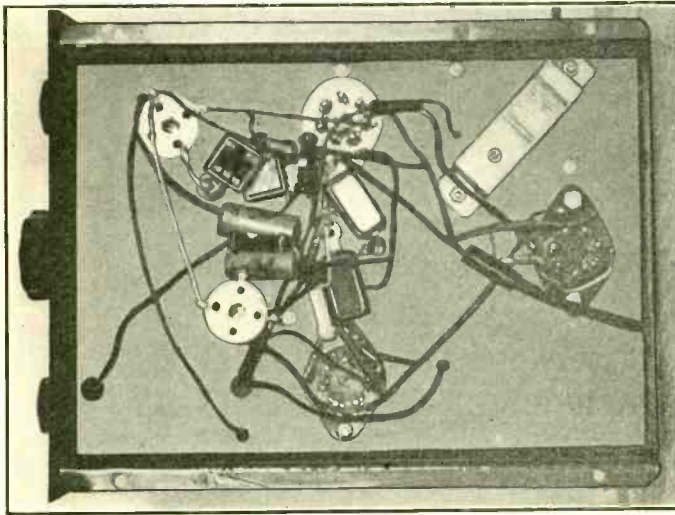

Bottom view of the multi-purpose device, showing the smaller parts. Small condensers and the radio frequency choke are to be seen here.

The oscillator in the first stage supplies one of the frequencies. This may be known by previous calibration or it may be the unknown provided a standard is available. The second oscillation, whether it be the known or the unknown, is impressed on the antenna-ground circuit. The comparison is effected by tuning the local oscillator to zero beat, a condition which is observed by means of the headphones. In this case the second tube acts only as an amplifier, especially of low audio frequencies.

UNIVERSAL POWER SUPPLY

If the beat frequency can be reduced below

the audible limit, the headphones are not effective. The range can be extended downward, however, by observing the beat on the ray indicator tube. When this is done the terminal marked G should be grounded. The low-frequency limit is here determined by the audio transformer. If this is a good one, heterodynes can be reduced to five cycles per second. To bring it down to within one cycle per second it is necessary to use direct, non-reactive coupling.

The circuit is arranged so that it can be operated on either A-C or D-C lines of 115 volts. The rectifier is a 37. Since all the tubes in the circuit are of the heater type and all require the same current, the heaters are connected in series with the line and in series with a 300-ohm ballast resistor.

The filter for the B supply is the typical pi-section of two 8 mfd. electrolytic condensers and on choke. A .1 mfd. non-reactive condenser could well be added to the second electrolytic, that is, to the one on the left in the figure, in order to provide better by-passing for the high frequency currents.

Since the circuit may be grounded on either side of the line, the chassis cannot be grounded independently. Hence there is a condenser of .002 mfd. in the lead between the chassis and the ground. Inasmuch as the antenna may be accidentally connected to ground, it is in the

interest of safety also to connect a condenser of the same value in the lead between the grid and the antenna. This must be connected so that it does not interfere with the leakage path provided by the radio frequency choke.

The ray indicator tube can also be used independently of the tubes that precede it in the circuit. The plate voltage is already provided. The signal voltage can be impressed between ground and the unmarked of the two input posts, or between the ground and the grid directly. In case a bias other than zero, the connection may be made between the grid and

the negative of the bias desired. The most probable application for this is to tuning receivers in which a diode rectifier is used. But many other uses suggest themselves. For example, one is the determination of the actual bias on an amplifier or detector tube. The ray indicator tube will give the correct voltage almost as accurately as a vacuum tube voltmeter. When it is used for this purpose the sensitivity will be improved if the 2-megohm resistor in the grid circuit is opened.

The layout of the parts is illustrated by three different photographs. The picture on pages

34 and 35 shows the side elevation. The 6E5 is directly over the variable condenser, the first 6A8 back of the condenser, and the second 6A8 near the back center. The 37 is hidden behind this tube. The audio transformer and the filter choke are also shown at the rear. The next photograph shows the parts under the sub-panel—sockets, small condensers, and the radio frequency choke. The third photograph shows the panel layout. One of the small knobs controls the bias rheostat of the first tube, as well as the line switch, and the other controls the inductance switch.

Front panel view of the multi-purpose device. The tuning control is in the center and the two auxiliary controls are flanking it. The ray indicator is directly over the dial and the input-output pin jacks are at the upper corners.

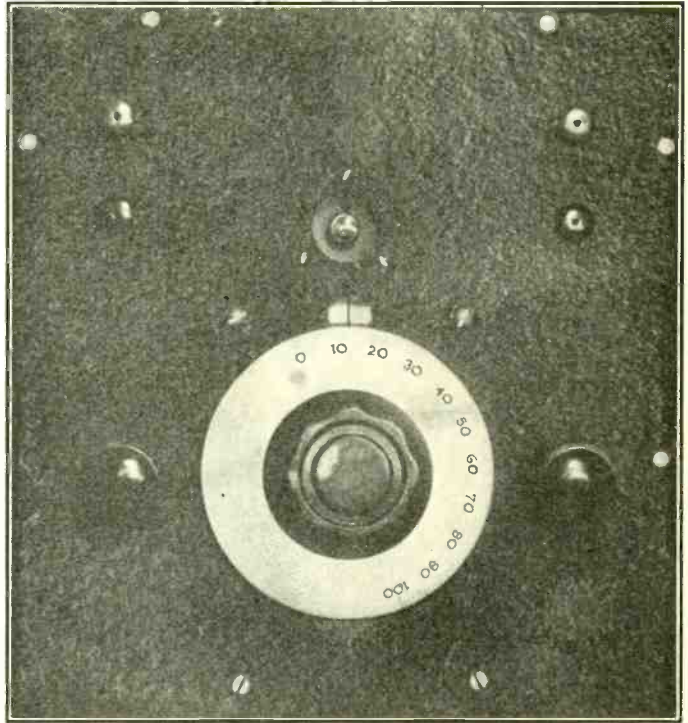

Small Coils Chosen for Price and Space Reasons

Much has been done about measuring the Q of a tuning coil, or more accurately, the Q of a tuned circuit. Most measurements are made for a better understanding of physical phenomena and for guides in the improvement of methods and devices. But what is the purpose of measuring the Q of a circuit? One reason, apparently, is to obtain a number for that number's sake. Measurements of the selectivity of tuned circuits have not been made, not for a long time at any rate, for the purpose of improving coils. On the contrary, they seem to have been made for the express purpose of making worse coils. If this has been

the true purpose, the results have been truly great. The change—shall we call it advance or decline?—has been from about 125 to 25. That is, the Q of an average tuned circuit is now one-fifth of what it was ten years ago and before.

The change in coil design has not been a scientific one, but strictly commercial. The question has always been: "How cheaply and how small can a coil be made and still be good enough to pass the minimum tests?" The answer now is: "The Q should be about 25 and the dimensions of shield should be about 2 inches diameter and 3 inches high."

I.F. Second Harmonic Interference Eliminated by Filters and Placements of Parts

By James Millen

General Manager, National Company

[In the November and December issues interesting technical facts about National Company's NC-100 receiver were presented. Here-with, in the final instalment, the solution of another problem is set forth, that of preventing squeals due to second harmonic of the i.f.—

INTERFERENCE due to generation of second harmonic currents in the second detector present a problem in the design of a receiver for which a high degree of excellence is the goal. The problem was successfully solved in the design of the NC-100 receiver.

OFFENSE BY HARMONICS

The nature of these whistles or "birdies" can be understood more easily by taking a specific example. Suppose that the i.f. amplifier is ad-

justed to a frequency of 456 kc. Of necessity, the second detector acts as a rectifier and harmonics of the i.f. frequency will appear in its output. Therefore, if the r.f. is tuned to a frequency of 912 kc it is very likely to pick up the second harmonic of the i.f., which is also 912 kc. If feedback of this sort does occur, it will result in a tunable whistle which sounds very much like a station carrier. This is true of the other harmonic frequencies also, and for the example given whistles may occur at 456 kc intervals, up to the sixth harmonic or so. Usually the even harmonics give more trouble than the odd, because they are stronger.

Such birdies are quite common in sensitive receivers, since the feedback from the detector is amplified not only by the i.f. but by the r.f.

(Continued on following page)

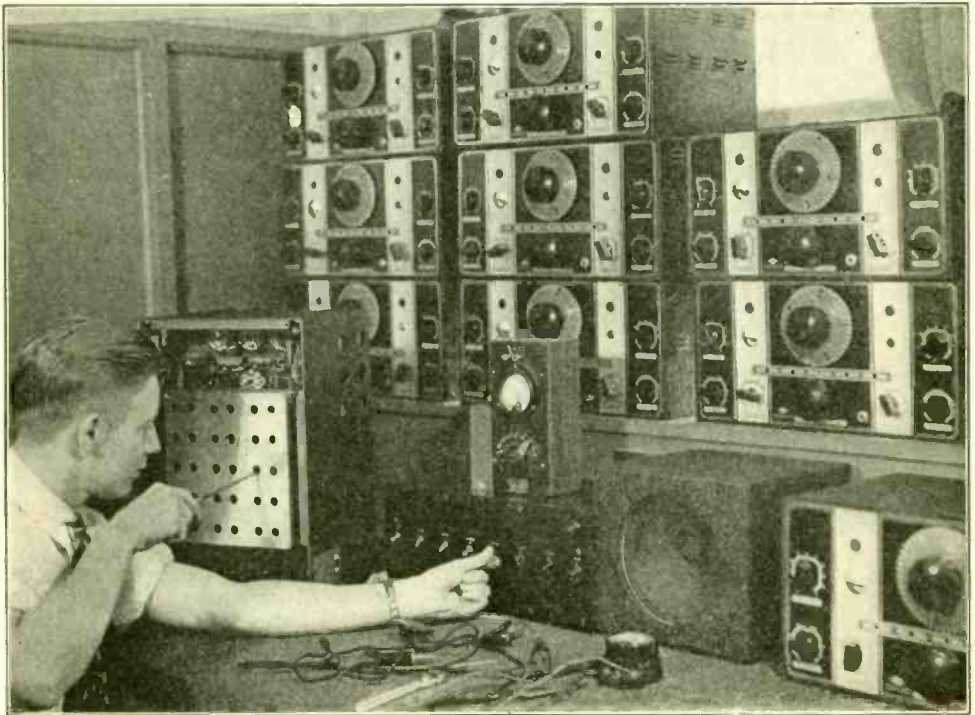

Multiple crystal oscillator for alignment of receivers in production. Any one of eight separate crystal oscillators, operating at selected frequencies in the tuning range of the receiver may be selected by its switch on the panel. The NC-100 receivers are under test.

Balanced Detector for Tone Push-Pull Output Developed for Drivers of Beam Power Tubes

By H. B. Joseph

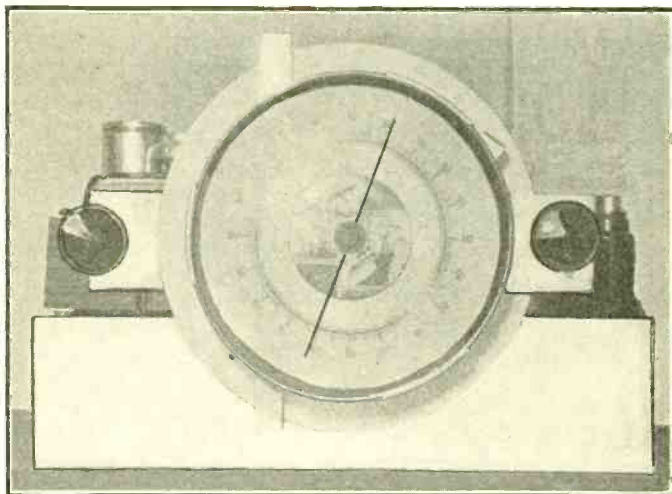

A unique method of control alignment was used. The airplane dial knob was located at right, as shown, by using spacers, setscrews and nuts to hold the dial frame taut with respect to the tuning condenser, without displacing the condenser plates forward or backward. A bracket at left holds the volume control.

THE eleven-tube superheterodyne shown in the diagram is distinguished by the inclusion of a balanced detector. The two diodes of the 6H6 are reversed in respect to each other, as shown by the fact that the anode of one is connected to the cathode of the other. Therefore rectification takes place over both alterna-

tions, or there is full-wave rectification. So the d.c. voltage across one load resistor is equal to the average of the a.c. input for one alternation, and the d.c. voltage across the other load resistor, during the next alternation of opposite sign, is equal to the same value so from the

(Continued on page 41)

Patience Solves Squeal Problem

(Continued from preceding page)

and the first detector as well. Under such circumstances very careful filtering of the second detector circuit is necessary.

A good deal of experimenting was necessary before the NC-100 was made entirely free from these whistles, and much of our effort had to be spent on layout. In some cases moving a single wire made all the difference between bad feedback or no feedback at all. The location of the by-pass condensers is also important. The plate by-pass condenser in the NC-100 had to be grounded at just one particular point, for instance.

No general rule can be given for curing this sort of trouble except to use plenty of patience

and common sense. The main thing to remember is that the second detector is usually the offender, even though the c.w. oscillator is usually blamed. Of course, the oscillator can (and sometimes does) cause this sort of whistle, but it is the exception that proves the rule.

This description has been concerned mostly with the problems associated with the detector and a.v.c. circuits because we felt that our experiences might be helpful. Naturally, our laboratory work on the NC-100 was not so simple as that. We could write a book on the subject of designing the coils, but it would not give information of much value to anyone else, and besides there were other problems, all solved successfully.

(Continued from page 39)

single plate to the joint plate-cathode of opposite diodes, the d.c. voltage accumulates. Hence the device is a voltage doubler.

With an output in d.c. terms equal therefore to twice the average a.c. full-wave input, since we must progress to the driver in push-pull fashion for this circuit, with center of the two joined load resistors grounded, half the output is delivered to one driver tube and half to the other. We therefore have unity voltage, instead of halved voltage for push-pull.

BEHAVES AS VOLUME EXPANDER

More than that, we have a volume expander circuit. This is automatically true, because the

are developed around the 6H6, so that bias alteration is introduced in the right sense, and the connections are a bit complicated. Here they are simpler and the remedy arises as much by accident as by design, since primarily the detector was developed for high-fidelity operation without regard to expansion.

The balanced detector was first suggested by Orval C. LaFrance in RADIO WORLD, several years ago for separate envelopes, and was later adapted by him to the single envelope 6H6 tube, since independence of cathodes was a requisite. He did remark on the better sensitivity to deep modulation, particularly the capability of excellent reproduction where 100 per cent. modulation is present, but did not spec-

CONNECTIONS TO 6H6 SOCKET, BOTTOM VIEW

The socket connections for the 6H6 second detector are shown. The i.f. transformer feeding it is not literal as to primary. Bottom view of the socket reveals the two separate diodes in the same tube are reversed in respect to each other.

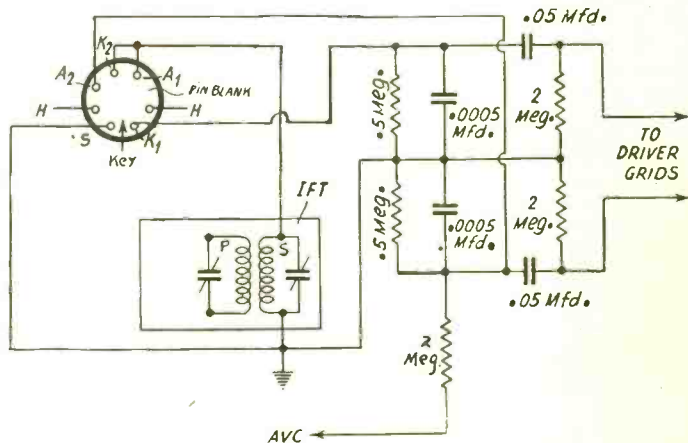

system is more sensitive to deep modulation than to shallow modulation. So the louder the signal the much louder the signal. This is an advantage because broadcasting stations necessarily practice compression, so that the actual modulation they introduce will not overtax the limitations of their systems. The greatest crescendos of symphonies therefore produce transmission modulations of smaller dimensions than the rendition alone would effect, but it would be senseless to permit more than 100 per cent. modulation, as this is simply a form of distortion.

So it is an asset in a receiver to have a circuit that works the other way, to restore that which has been taken away, and therefore enable reproduction with still greater volume realism than is present even in the transmitter circuits!

Only in recent months has the idea of volume expansion been promoted seriously, the principal application being to phonograph amplifiers, because of the more rigid compression practised in recording. But the same idea is applicable to receivers, though the quality of expansion need not be so great.

DETECTOR DUE TO LA FRANCE

Standard circuits for practice of expansion

cifically associate this with counteraction of station compression.

Since all stations use amplitude modulation in sending out programs, the unmodulated carrier produces a certain amplitude, and at 100 per cent. modulation the complex wave has an amplitude twice as great as that of the carrier alone. Indeed, the wave may be so complex, when music-modulated by the orchestral effort, that it practically defies very precise measurement of modulation, because the percentage is ever changing, and at such a rapid pace that the measuring instruments and notations can not follow quickly enough.

LISTENING TEST

Two tones are sometimes used, for instance, for comparisons of modulation percentages, where speech alone is presumptively simulated. For the simplest case a single tone is considered, when the percentage modulation equals $100d/E$, where d is the difference in voltage between the unmodulated carrier and the modulated carrier, and E is the voltage of the unmodulated carrier alone. It is therefore apparent that a listening test has some value, where instruments themselves do not give a

(Continued on following page)

(Continued from preceding page)

faithful report of percentage modulation, of a very complex wave.

The listening test was applied to a group when an orchestra was playing. One person remarked that the orchestra had a lot of pep. Another said that the musicians played at a greater variety of sound levels than most orchestras. Somebody else, when asked, remarked that the rendition sounded as if really an orchestra was playing. The main idea therefore was grasped by the commentators, although none of them was particularly versed in music, nor had any idea of radio technique applied to the more faithful reproduction of what and how the orchestra played.

SOUNDS BETTER

So by the listening test alone it is practical for anybody to tell that there is a difference, that it is in the direction of improvement, and that the effect is pleasing, and may even be dramatic. When a symphonic orchestra crashes forth its stoutest passages in great crescendo, it is certainly an advantage to have the reproduction follow like a shadow, rather than trail indifferently like a clothespin on a kite tail.

What applies to the percentage modulation also applies somewhat to the carriers, so that strong stations tend to come in stronger and weak ones weaker, since the rectification action does not distinguish between the com-

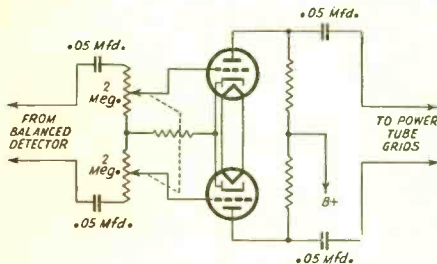

The use of a dual potentiometer. The dual 2 meg. is hard to obtain, so dual .5 meg. may be used instead, if that is the highest value dual readily obtainable.

ponents of the radio frequency until after the tube has performed its rectification function, and not even then, unless the rectifier output has been filtered, so that carrier effects are bypassed, and even some of the highest audio frequencies. Thus a.v.c. becomes doubly imperative.

A.F. PASSES 20 KC

It is possible to get through the audio amplifier frequencies as high as 20,000 cycles, with small attenuation. It is therefore clear that the high audio frequencies are more than well handled, since 9,000 cycle modulation is "tops" and 7,500 cycles common, so the limitation, if any, would be imposed at the other end. However, with ample baffle for a good speaker, and stopping condensers of negligible reactance compared to the load resistance, the low notes can be handled as well. For instance, with 2 meg.

load compared with .05 mfd. capacity, at 60 cycles the load would be about 40 times as high, which is ample. It is necessary, however, that the stopping condensers have *lowest possible leakage* (highest resistance on leakage test), hence they would be paper condensers *specially checked or selected for lowest leakage*.

Since the circuit is distinguished by the detector, and is practically standard as to the rest, most attention might be devoted to the detector. Since it should be a balanced detector, and will not necessarily balance itself, the balance has to be introduced or at least checked. The problem will be discussed both from the approach of the detector itself and the audio channel as a whole. In reality the balance applies to the whole circuit consisting of the detector, the two driver tubes and the two output tubes. If the circuit is balanced it is balanced, as any unbalance in the detector may be offset in the driver, or unbalance in the driver or detector offset in the output tubes.

However, to avoid an endless chain of technique on the subject of balance, the behavior of the 6H6 to radio frequencies will be considered, then the audio circuit to audio frequencies. First, it must be assumed that the two diodes of the 6H6 are not equal. They seldom are. If the same a.c. voltage is applied first to one diode, and then to the next, with accurately equal load resistors, the rectified currents will differ. More resistance may be added to the load resistor in the circuit where the current was greater, until the current is now reduced to the same value as found in the other diode. This balance is dynamic because related to a.c., since no d.c. actuates the device, but merely results from the application of a.c.

SECOND HARMONIC TEST

When the circuit exists in its entirety, with the tentative rearrangement of resistance load values as suggested, the receiver is tuned to a signal frequency twice the intermediate fre-

Compound Control Has Its Advantage

The location of the manual volume control, as shown in the circuit diagram, is not the best possible, because it reduced the excitation of the second detector. The method works well enough for reception of strong local stations, the ones the author happened to be most interested in, but for wider service it would be preferable to move the control to the audio end.

That would require the use of a dual control. A tandem 2 meg. potentiometer in the 6C5 grid circuits would be acceptable. The leads looking out of the grids would be connected to the sliders, otherwise the circuit would be as shown.

quency. Since 465 kc is suggested, if the set is built with that i.f., the frequency to select is 2×465 kc or 930 kc. You may not know just where 930 kc should come in, but can approximate the dial position, and when the right setting is found there will be a squeal. This is due to the second harmonic of the intermediate carrier. All detectors and rectifiers supply such a content, which would pass unnoticed save for the fact that some station is operating at or near twice the intermediate frequency, the receiver is picking it up, even if only as a carrier too feeble to actuate the detector without assistance, for that assistance is provided by the second harmonic of the generated i.f. Hence we have a beat. If there is a station on 930 kc the beat will be zero for a generated i.f. of exactly 465 kc. The accuracy of the alignment of the i.f. channel itself does not affect the tone of the beat, or dial position, but affects only the strength of the result.

But the interfering station may not be 930 kc, because the generated intermediate frequency itself is not exactly 465 kc, regardless of what frequency the i.f. channel is tuned to, because the tracking may not be perfect in the

tuner, so that the i.f. produced is not exactly the frequency to which the i.f. channel is tuned.

I.F. REALIGNMENT

If there is a beat that can be heard (meaning other than zero), the i.f. may be realigned to bring out this beat most pronouncedly. The rest of the circuits having been tied down (r.f. and oscillator), no molestation of their settings is now permissible, as we have acted upon the third comparison point, the one usually considered theoretically but not honored with any application. *Now we have a method of applying precise tiedown at about the geometric mean of the standard broadcast band.*

All we have done to the detector so far is to balance it as best we could by a resistance compromise on the basis of unequal diode conductivities, and align the i.f. channel so that it corresponded with the real intermediate frequency region generated when the dial was set for about the middle of the broadcast band.

We did note that a squeal is bound to be heard, provided there is sufficient antenna in-

(Continued on following page)

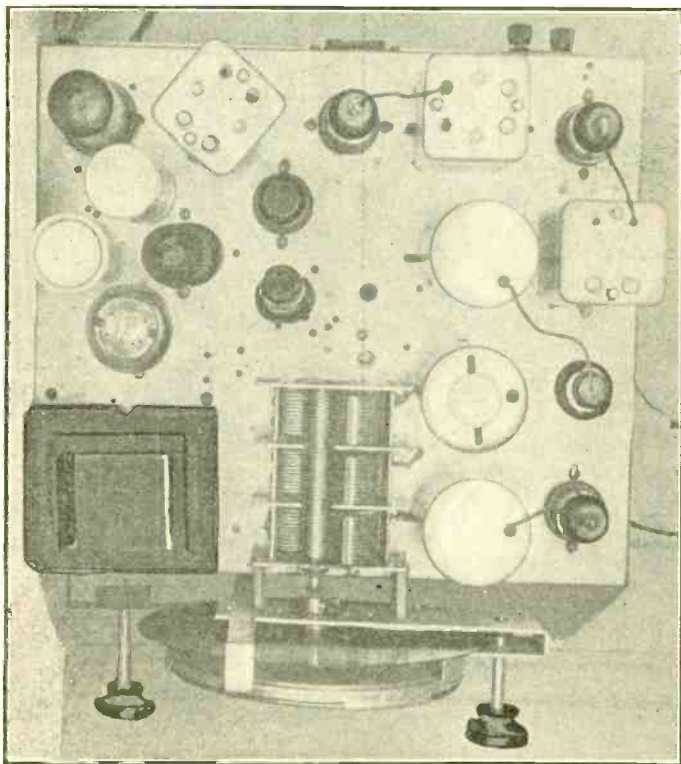

Two of the tubes occupied sockets on special brackets underneath the chassis, hence are not visible. The tube at lower right is the 6K7 r.f. amplifier, next is the 6A8, then the 6K7 first i.f. tube. Note that for two i.f. transformers the leads emerge from the can tops. In the diode feed all four leads emerge from the bottom of the can.

How to Wind Coils for Balanced Circuit

The two radio-frequency transformers are wound identically, with 127 turns of No. 32 enamel wire on one-inch diameter tubing, insulation wrapper between this secondary and intended primary, which consists of 35 turns of any fine wire, including the kind of wire used for the secondary. The insulation may consist of Empire cloth, or even wrapping paper, one turn of cloth being enough, two turns of paper. The primary is near the end of the secondary that is to be used as ground, not low enough so that the end of the two windings will be parallel, but so that the end of the primary sits about one-quarter to one-half inch farther up.

The oscillator coil consists of a secondary of 74 turns of No. 32 enamel wire, insulating wrapper between, and 35 turns of any fine wire, including the kind used for secondary, wound over the center of the secondary. The tubing diameter is one inch.

The foregoing instructions for winding both types of coils intend that the coils be put in aluminum or copper shields of inside diameter not less than 2 inches, and that the coils be located centrally within the shields.

Tight winding applies in all instances.

If no oscillation is produced, reverse the external connections to the oscillator plate winding, e.g., lead that went to G2 would go to the .02 meg. limiting resistor, lead that went to that resistor would go instead to B2, which is in a sense the plate of the local oscillator.

(Continued from preceding page)

put, and it may be necessary, for a beat with a far-distant station to listen with ear to the speaker, so weak may the squeal be, but the beat will be there for almost any station on earth that is transmitting in this frequency region.

A local station on 930 kc, for 465 kc i.f. generated, would produce a loud scream. A station in Cuba, Mexico or Europe could produce a response, and the audio frequency of this note is represented by the difference between twice the intermediate frequency, on the one hand, and the frequency of the station on the other, e.g. $(2 \times 465) - 925 = 930 - 925 = 5$ k.c. note. If by accident there is zero difference between them when the set is tuned to twice the i.f., the note will be heard when the set is tuned to a little more or less than twice the i.f. Always there is a note.

Now, the object of all the discussion of the effect of the second harmonic content of the i.f. carrier is to reduce the intensity of the note by application of further and closer remedies

to the detector, since *reduction of the intensity of the note will mean reduction of amplitude of the second harmonic*. It will not be possible to eliminate the second harmonic completely by this extra balancing nicety, but it may be possible to reduce it considerably, principally by putting a .000365 mfd. or so variable condenser across one, then the other of the detector load bypass condensers (marked .0005 mfd.), and noting whether the intensity is reduced at some particular setting of the condenser. If so, a fixed capacity equal to the amount of variable condenser capacity then in circuit is introduced across the proper fixed condenser. All the rest of the circuit must be functioning when this work is being done, as some of the subsequent circuits produce effects reflected back to the 6H6.

The balance undertaken by use of the second harmonic content and beat is related to radio frequencies. The rest of the circuit may require some attention. A large capacity should be put across the 5,000 ohm (.005 meg.) biasing resistor of the 6C6 push-pull driver stage. There should be no difference in quantity of sound whether the condenser is in or out, for if inclusion results in increased sound, there is audio unbalance, probably in the driver stage.

TEST FOR OUTPUT STAGE

The same condenser, if no difference showed up in the driver test, may be moved to the 125-ohm 6L6 biasing resistor, requiring change of only one lead, and again if there is increase of volume there is unbalance.

In any instance, the no-signal plate current of one tube in the stage under investigation is measured, then the tube from the companion part of the stage is put in the socket leading to the meter, and the reading is noted. For the 6C5's, plate load resistor adjustment—using higher resistance to keep the current the same for tests of both tubes—should be applied, until the bypass capacity across the 5,000 ohms does not seem to produce any effect. Then for the output stage, a modulated r.f. signal is applied to the set input, preferably from a signal generator, though a station may be used in a pinch, and in series with the grid load resistor is put a 500,000-ohm variable resistor, used as a rheostat, between the .05 mfd. and the 2 meg. power tube grid load, grid connected to slider. Then the slider is moved over its full span, in small steps, condenser in and out of the 125-ohm biasing circuit for each rheostat setting, and if the condenser becomes more and more effective, the rheostat is put instead in the other leg, previously altered circuit closed, and the test renewed until the condenser produces no difference, capacity in or out. Then the used part of the rheostat resistance is measured and a fixed resistance of that value substituted, meaning that grid of the particular power tube does not get its maximum possible voltage, but the full voltage appears across the sum of the 2 meg. and the added resistance. The power tube grid goes to the joint of these two resistors, the added resistance being nearer the stopping condenser. Now the two power tube grids get the same voltage.

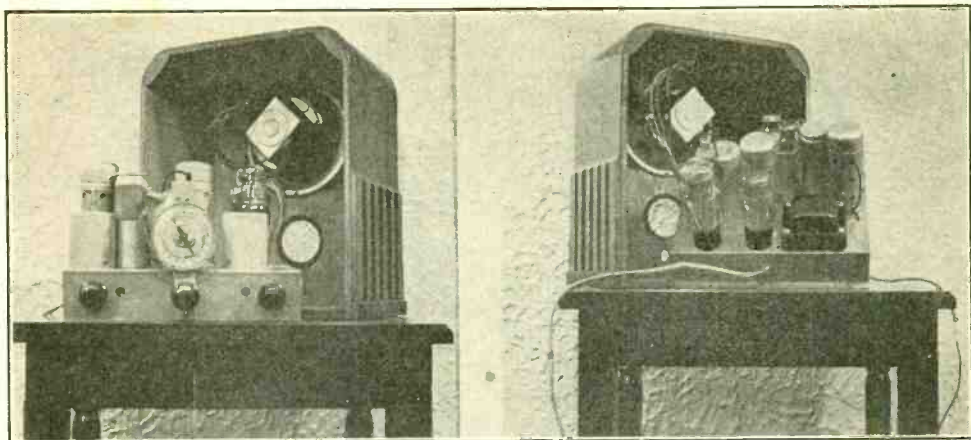

Views of the chassis seen from front and from rear, with a "picked-up" cabinet in background.

A Small Standard Super Excellent Performance on Five Tubes

By M. N. Beitman

THE set builder interested in obtaining maximum results with good efficiency and economy of parts will find the simple five-tube broadcast superheterodyne an inviting set. The absolute minimum of parts and stages is employed and the circuit is especially stable and easy to adjust.

An examination of the schematic diagram will disclose the circuit to be standard. With a type 2A7 tube as a pentagrid converter, the functions of the first detector and oscillator are combined in a single tube. A two gang variable condenser is used. A padding arrangement of two condensers in parallel is used in the oscillator section. The fixed condenser is of .0008 mfd. capacity and the semi-variable is of the 60-400-mmfd. type.

AVOIDING POSITIVE GRIDS

A single stage of intermediate-frequency amplification provides ample gain. A type 58 tube is used for this purpose and since the set is used only for the broadcast band, 175 kc intermediate frequency gives somewhat better results than the higher i.f. usually employed in sets incorporating short-wave reception.

The original model was built with air-core double-tuned i.f. transformers.

The second i.f. transformer, feeding the diode of the type 2A6 tube, must be of the output type since it works into finite impedance of the diode.

The automatic volume control voltage is applied to both the 2A7 and the 58 tubes, giving the required amount of action.

The a.v.c. is developed across the diode load

resistance, hence at no signal the steady bias on the controlled tubes should be higher than that on the triode of the combination detector-amplifier. This may be checked by noting that controlled tubes' plate current is moderate. If excessive, due to positive grids, increase the 400 and 300 ohms in both instances.

TONE CONTROL INCLUDED

The triode section of the 2A6 is used for audio amplification and drives the type 47 pen-
(Continued on page 47)

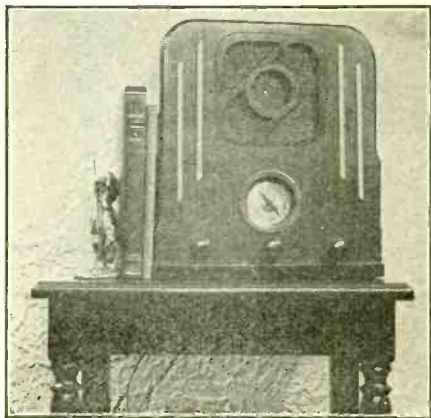

Here's how it looks on a small table in the living room, made homelike by the book end and two volumes.

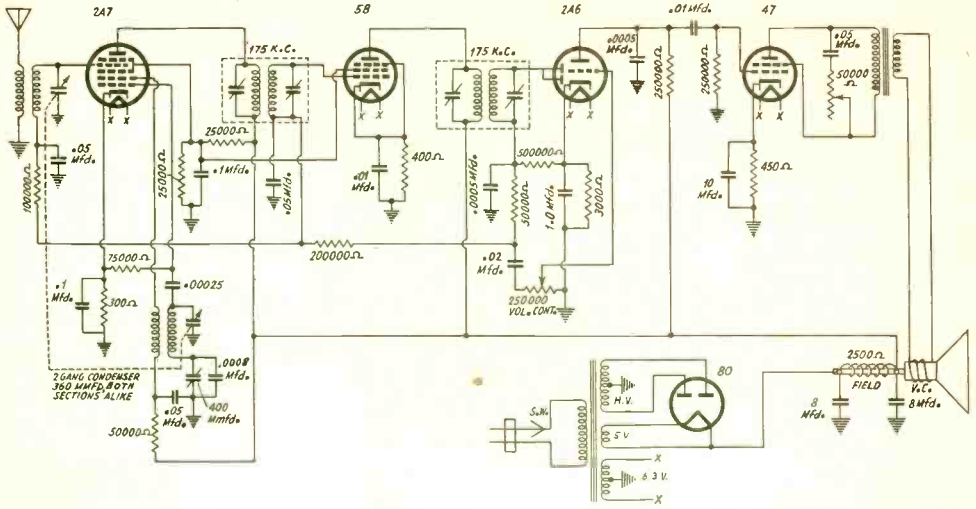

The circuit is standard. The r.f. coil has 240 microhenries for secondary, the oscillator coil 202 microhenries for secondary, as the i.f. is 175 kc. The tuner coils are commercially obtainable.

LIST OF PARTS

Coils

One antenna coil
 Two double-tuned, 175 kc i.f. transformers (Hammarlund). One has all four leads through bottom of shield
 One power transformer; 5 volts, 2 amp.; 2½ volts, 4.5 amp.; high voltage 360-360 volts, 50 ma.

Condensers

One .00025 mfd. mica condenser (Cornell-Dubilier)
 Two .0005 mfd. mica condensers (Cornell-Dubilier)
 One .0008 mfd. mica condenser (Cornell-Dubilier)
 One .01 mfd. 600 volt condenser (Cornell-Dubilier)
 One .02 mfd. 600 volt condenser (Cornell-Dubilier)
 Four .05 mfd. 400 volt condenser (Cornell-Dubilier)
 Three .1 mfd. 400 volt condenser (Cornell-Dubilier)
 One 1. mfd. 200 volt electrolytic condenser (Cornell-Dubilier)
 One 10. mfd. 35 volt electrolytic condenser (Cornell-Dubilier)
 One oscillator padding condenser, 60-140 mfd. (Hammarlund)
 One two-gang .00036 mfd. variable condenser

Resistors

One 250,000-ohm volume control with a.c. switch attached
 One 300-ohm ½ watt resistor
 One 450-ohm 2 watt resistor
 One 3,000-ohm ½ watt resistor
 Two 25,000-ohm 10 watt resistors
 Two 50,000-ohm 1 watt resistors
 One 50,000 ohm tone control potentiometer
 One 75,000-ohm ½ watt resistor
 One 100,000-ohm ½ watt resistor
 One 200,000-ohm ½ watt resistor
 Two 250,000-ohm ½ watt resistors
 One 500,000-ohm ½ watt resistor

Other Requirements

One four-prong wafer socket
 One 8-8 mfd. electrolytic condenser, w.v. 525 volts (Cornell-Dubilier)
 One airplane dial and escutcheon
 Three knobs
 One 2½-volt pilot bulb
 One 6-inch dynamic speaker, with 2,500 ohm field and output transformer to match type 47 tube
 Tubes, types 47, 2A6, 2A7, 58, and 80 (Sylvania)
 Hardware and hook-up wire
 One small seven-prong wafer socket
 One 10x12 inches chassis base
 One a.c. line cord and plug
 Three grid clips
 One five-prong wafer socket
 Two six-prong wafer sockets
 Two tube shields

AERIAL

Length is Important

By Lewellyn Brooks

THE need of pre-selection is often stressed for superheterodynes, and yet small supers, even using only a two-gang condenser, are common, and the question arises whether there can be any reconciliation.

higher the selectivity, for the short antenna is a special case of loose coupling.

The same principle applicable to the small set applies to the larger set. The antenna length may be greater for greater pre-selection built into the receiver. Hence, in general, the bigger the set, the bigger the aerial it will stand. And the more antenna energy picked up, the higher the ratio of signal to noise, or the less comparative noise.

PICK-UP BEST LOCATED IN TUBE'S GRID CIRCUIT

The best place to connect a phonograph pick-

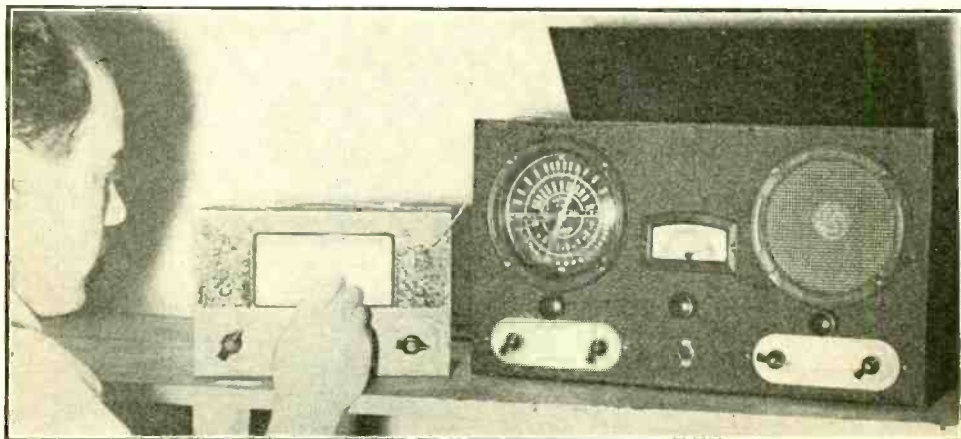

Inject a voltage of the frequency a super is tuned to, then a voltage of that frequency plus twice the intermediate frequency, measure them and get the image ratio.

The small set must have a short aerial, meaning one electrically short, i.e., not picking up very much energy. This may be accomplished by a physically short aerial, or a longer aerial with a small series condenser connected between antenna and receiver.

Since there will be squeals due to inadequate pre-selection when an electrically long aerial is used, the length is reduced until the squeals are sufficiently reduced, or disappear. This is possible because the looser the coupling the

up unit is in the grid circuit of an audio amplifier tube. Just which tube, depends on the strength of the picked-up voltage. Very likely it will be so weak that the output will be too low if the voltage is impressed on the grid of the power tube. Hence the preceding tube should be used. If that gives too much output and causes overload distortion, the voltage should be adjusted by means of a voltage divider, or what is ordinarily called a potentiometer.

(Continued from page 45)

tode output tube. A full-range tone control is connected in the output circuit of the final stage for stressing either treble or bass at the different occasions may demand.

The power supply is the standard type 80 tube circuit using an inexpensive half shell power transformer. The speaker field serves as the choke and the dual 8 mfd. electrolytic condenser provides plenty of filtering action.

The set is illustrated with an improvised cabinet originally used with a much older commercial set. A cabinet suitable for this set may be obtained for a song from a local radio dealer. Usually the cabinets available will have an opening for a drum type dial and a larger hole can be cut for the escutcheon of the airplane dial. It is advisable to obtain the cabinet first and then drill the chassis to fit the holes in the cabinet's panel.

Variable A.F. from Generator

R.F. Device Also Enables Condenser Leakage Tests

By Henry Burr

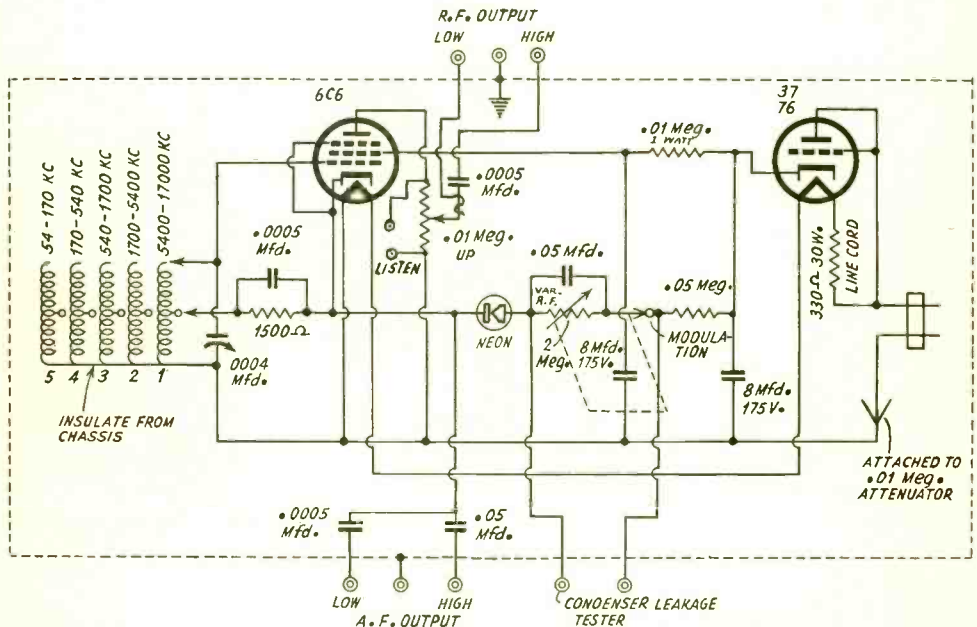

Extending the use of a signal generator, by having a neon tube modulator. The audio frequencies produced may be varied considerably, perhaps in a ratio of 50 to 1, with a 2 meg. rheostat, and the a.f. may be taken off separately. High and low intensity outputs for both r.f. and a.f. also are provided. Low r.f. output is due to a few turns tightly wound around lead as shown. Condenser leakage tests may be made in conjunction with the neon lamp.

WHEN a signal generator is equipped with audio oscillator, called modulator, independent posts may be provided so that the audio voltage may be taken off, for use in checking audio amplifiers suspected of being operative or defective. Even if only a single tone is obtainable, the service is valuable.

If the audio oscillator is a neon tube, two more posts and a limiting resistor provide a method of checking filter and other condensers for leakage. If the neon tube, which should be so placed as to be visible from the front panel, lights up more rapidly than once a second the condenser under test may be regarded as having too great leakage. This applies particu-

larly to electrolytics of voltage ratings greater than 100 volts. For lower-rated electrolytics the test does not quite suffice, as the condenser may be considered good even if the flashes are more numerous than stated. Paper condensers normally would be given a more rigorous requirement, say, a flash more than once every three seconds would rule the condenser out.

FREQUENCY APPROXIMATION

If the neon tube is used as audio oscillator, the frequency generated depends mostly on the amount of series resistance and the capacity across that resistance. Either capacity or resistance may be increased to lower the fre-

LIST OF PARTS

Coils

Five tapped oscillator coils to cover range from 54 kc to 17,000 kc in five steps with .0004 mfd. tuning condenser.

Condensers

One .0004 mfd. precision tuning condenser (only a particular, special condenser will track the frequency-calibrated scale.

Two .05 mfd. Three .0005 mfd. Two 8 mfd., 175 volts.

(Fixed condensers are products of Cornell-Dubilier.)

Resistors

One 1,500 ohm. One .01 meg., 1 watt. One .05 meg.

One potentiometer, 10,000 ohms up, with a.c. switch attached.

One rheostat, or potentiometer used as rheostat, 2 meg., attached switch used for modulation on-off.

One line cord and plug with 330-ohm, 30 watt resistor built in.

(Resistors, except line cord, products of International Resistance Company.)

Other Requirements

One metal box. One chassis. One metal panel.

One frequency-calibrated scale, to be affixed to panel.

One double-pointer knob to be affixed to variable condenser shaft.

One six-hole and one five-hole socket.

One Sylvania 6C6 and one Sylvania 37 tube.

One grid clip for 6C6.

Two knobs, one for r.f. attenuator, one for a.f. rheostat.

Six insulating washers, three to be put between tuning condenser frame and upper side of chassis, and three between condenser mounting screws and under side of chassis. This, with large enough hole for condenser shaft to clear the front panel, insulates the line from the metal chassis, panel and box.

One neon lamp, wattage unimportant, but no limiting resistor should be built in and lamp must be of type that works on d.c.

One number plate, 1, 2, 3, 4 and 5, for coil switch.

One plate for r.f. attenuator.

Eight binding posts.

quency, or both may be increased. To increase of frequency either or both may be lowered.

It is handier to produce large changes in a single unit by using resistance variation, hence a rheostat, or potentiometer used as rheostat, one terminal idle, serves excellently. Thus a 2 meg. or higher rheostat serves to change the frequency sufficiently for a ratio of nearly 50 to 1. The time constant for the combination of full resistance, 2 meg., and .05 mfd. is $2 \times .05 = .1$, and the frequency is the reciprocal of .1, or $1.1 = 10$ cycles. Actually the frequency is somewhat higher as the time constant formula alone does not take into consideration all the factors. These include the applied B, the ignition and extinction voltages particularly. The ignition voltage may be assumed to be 70 volts and the extinction voltage 20 volts, but these are just averages, and may actually be different in particular instances.

MINIMUM RESISTANCE

However, once the variable frequency feature is included, the settings of the rheostat may be calibrated as to frequencies. It is necessary to have some standard of frequency.

The line frequency of 50 or 60 cycles, whatever it may be, is sufficiently accurate for the present purpose, and harmonics thereof may be used in conjunction with a cathode-ray oscilloscope up to the tenth, or 500 or 600 cycles. Subharmonics may be used, also, for 30, 20, 15, 12 and 10 cycles, for the 60-cycle case, also with the oscilloscope.

Some sort of audio oscillator would have to be set up at 100 cycles for harmonics determined for above 500 or 600 cycles in 100 cycle steps, to the uppermost limit.

The factor influencing this limit, considering a fixed condenser in use, such as .05 mfd., is the minimum resistance setting of the rheostat. Since the maximum setting is high, the minimum may be far from zero resistance, even a few thousand ohms, especially as the modulation on-off switch is on only when some sizeable resistance is in circuit, for mechanical reasons.

GOOD AND BAD CONDENSERS

So besides the regular generator service of producing radio frequencies, modulated or unmodulated, we have variable audio frequencies

(Continued on following page)

for modulation, also separate output for these variable audio frequencies, and besides can test condensers for leakage. The modulation on-off switch is put on the off position when the leakage test is made, as the B feed to the neon tube is then open, and the extent to which the condenser under test closes this open is a measure of the condenser leakage.

It has been stated that the condenser test is valuable, also that it is not infallible. The limitation is imposed by the fact that the condenser's d.c. resistance is being tested, as to its effect in production of flashes, whereas for electrolytics the condition of the formation of the firm deposit is not absolutely and infallibly determined by a resistance check. The formation may be better than the resistance check discloses, but the limitation is in the right direction, since a condenser is rejected even

served by the seemingly reversed sequence of plate position numbers to frequencies. That is, the plate numbers increase as the actual frequencies decrease.

NEW BOOK BY JONES

Frank C. Jones has written "Jones Radio Handbook," formerly called "The Radio Handbook."

"Jones Radio Handbook" is a new book, containing hundreds of new circuit diagrams, photographs and a wealth of new material not previously published. It contains almost 500 pages. It has seventeen chapters. It contains complete data on practically all phases of radio vital to the amateur, as well as an abundance of theory for anybody else interested in the technical side of radio.

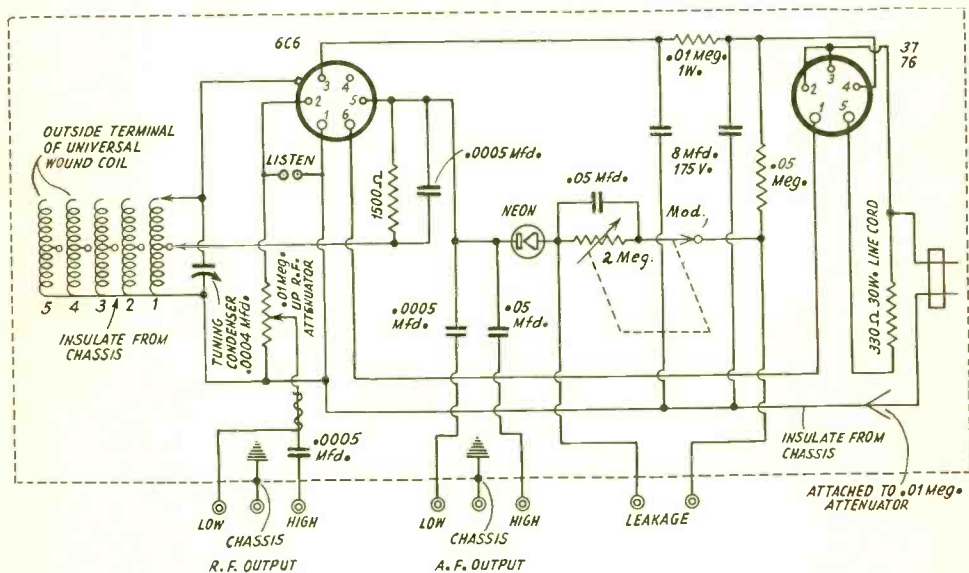

The wiring as it appears in relation to sockets viewed from bottom. This partly schematic coincides exactly with the other wiring diagram.

though it may possibly be good in some rare instances, rather than being accepted though it may be bad.

The frequencies covered by the radio oscillator, using a .0004 mfd. condenser, and five tapped commercially-obtainable coils, are 54-170 and 170-540 kc for the two bands calibrated. The rest of the bands repeat these decimally, so that the switch coil switch plate numbers correspond as follows to the frequencies:

- 1 = 5,400-17,000 kc
- 2 = 1,700- 5,400 kc
- 3 = 540- 1,700 kc
- 4 = 170- 540 kc
- 5 = 54- 170 kc

WIRING CONVENIENCE

The convenience is wiring in the coils, with wire lengths properly apportioned to the coils, shorter lengths for higher frequencies, is better

SOCKET PRECAUTION

Sockets not possessing excellent insulation often break down in 6L6 push-pull output stages, due to high voltages at audio frequencies.

Easy to Duplicate Circuits We Print

PARTS for all circuits described constructionally in RADIO WORLD are obtainable. If trade names are not identified in text, identification can be obtained quickly by addressing Information Editor, RADIO WORLD, 145 West 45th Street, N. Y. City.

More Controls Calibrated

Advance Made in New Model Super-Pro

By Donald Lewis

BAND WIDTH

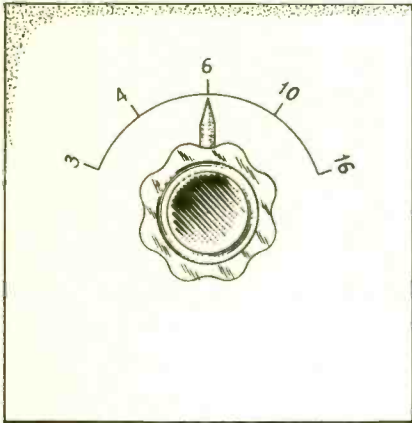

SENSITIVITY

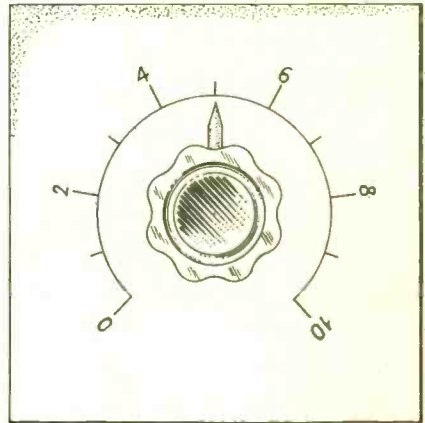

Detail of the calibrated band width and sensitivity controls.

MANY new features have been incorporated in the model Hammarlund "Super Pro" professional receiver just developed in the communication engineering department of the Hammarlund Mfg. Co., Inc.

A combination of glass and metal tubes is

used—eight metal tubes and eight glass tubes—to obtain the advantages afforded by both types in respective circuits.

One of the features is a five-range band width scale, engraved on the front panel. With the aid of this tuning device it is possible, for the first

(Continued on following page)

AUDIO GAIN

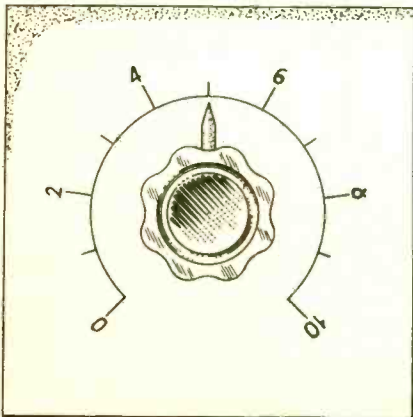

BEAT OSCILLATOR

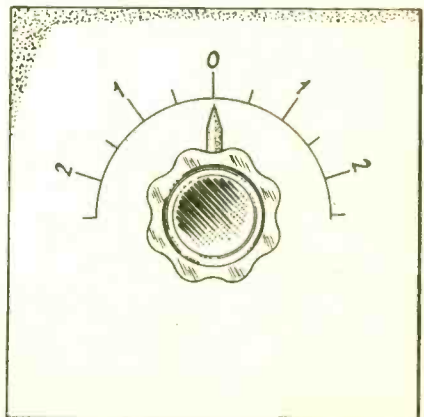

The same general scheme is applied to the audio gain and beat oscillator controls.

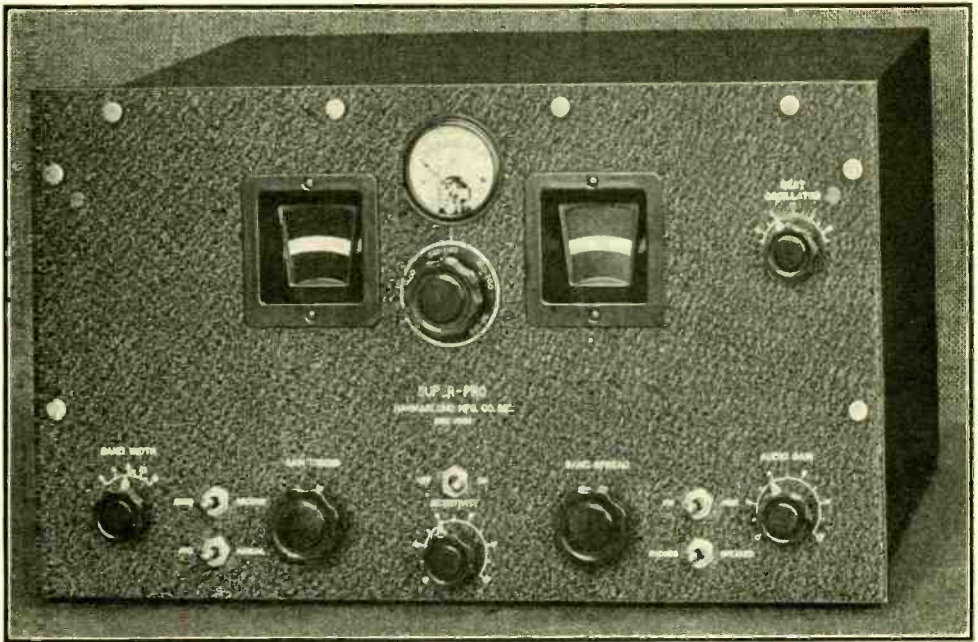

Front view of the new model professional receiver developed by Hammarlund. Note the control calibrations.

(Continued from preceding page)
time, accurately to select the actual band width desired. That is, if the operator wishes to tune to, let us say, a band width of 3 kc. or 16 kc., he can actually turn the knob to either one of these calibrations on the panel.

A new calibrated sensitivity control and audio gain control represent two more features. The calibrations of both these controls also appear

directly on the panel and enable the operator to select the proportionate sensitivity or audio gain required for each signal. Thus, an actual calibrated tuning table can be made for signals from any station.

For the operator interested in C. W. signals there is an additional feature—a calibrated beat oscillator control. With this unit it is possible
(Continued on following page)

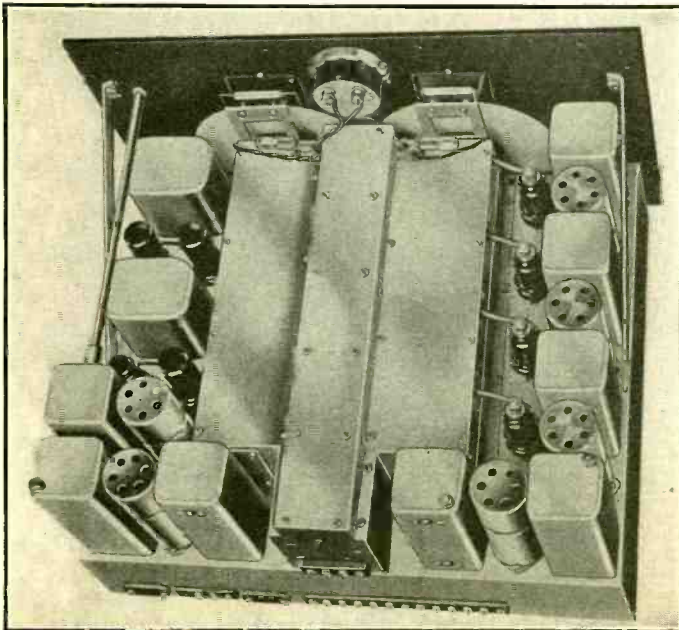

A symmetrical arrangement marks the chassis. Note how extensively shielding is introduced, also the combination of metal and glass tubes, the latter in the perforated shields.

LEAKAGE

Not Always Vice

By Brunsten Brunn

CONDENSER tests for leakage have been devised. The descriptions of these tests have emphasized, by implication, that it is important that the leakage of a condenser be low. While it is true that a high insulation resistance is a desirable quality in a condenser, it is not true that a condenser having considerable leakage is always undesirable. There are many important applications where a high leakage of no importance, and a few where the leakage is actually an advantage.

Suppose, for example, that the condenser is used across the B supply, that is, in the filter. Suppose, further, that there is no bleeder in the circuit. In this set-up a considerable leakage is an advantage, because it prevents excessive voltage when the power is first turned on, or before the amplifier tubes have heated sufficiently to draw current. Even after the circuit has settled down to a steady state the leakage is not detrimental. It merely adds a little to the total current drawn from the rectifier, but this addition may be negligibly small in comparison with the current drawn by the tubes.

WHEN LEAKAGE IS NEGLIGIBLE

It may be said that the leakage is negligible whenever the condenser is used for by-passing a d.c. circuit. For example, consider the condenser across the grid bias resistor of a tube. The current through the tube and the bias re-

sistor may be of the order of 10 milliamperes. The leakage might amount to one per cent. of this. Even if as high as 10 per cent. it would make little difference. If it is greater than that, as it may be in certain cases, it is perfectly all right to use the condenser provided that the leakage is taken into account in computing or determining the value of the resistor. It is seldom that the leakage is so great that any account need be taken of it in such computation.

When the condenser is used for blocking d.c. it is important that the leakage be as low as possible. In some cases it is not even possible to get a leakage that is sufficiently low. Therefore a condenser may be rated 100 per cent. When it is used for by-passing and zero per cent when it is used for blocking.

The most critical position for a stopping condenser is that between the plate of one tube and the grid of the next in a resistance-capacity coupled circuit. Here the total leakage should be nil. But this ideal condition cannot be brought about because, even if the stopping condenser is leak-proof, the various insulators between the grid and the plate are not. There will be leakage from the plate to the grid and therefore there will be current through the grid leak.

CASE OF OVERHEAD GRIDS

Most of this undesirable leakage comes from the plate of the same tube. That is, the leakage takes place through the socket. This is minimized when the grid is at the top of the glass, or metal, envelope. In such cases most of the leakage may be through the stopping condenser and through the supports of the condenser, resistances, and sockets.

When there is appreciable leakage to the grid of a tube, through the stopping condenser or the various insulators, the mean grid bias of the tube is less than it is supposed to be because the grid end of the grid leak is more positive than the ground end. This effect is negligible if the grid leak resistance is low, but it may be very great when the resistance is high. Indeed, the grid may actually go positive. In such cases the amplifier does not work.

(Continued from preceding page)

accurately to select a beat note from just about 0 to 2,000 cycles on either side of the carrier, with intermediate values available too.

By adjusting the band width control, a tone control effect is also available, since the high or low notes can be cut off or heard at will, depend upon the band width selected. An additional feature of this model is the special cam switch having five shielded sections with five silver-plated bakelite knives in each unit. Each knife glides into four silver-plated phosphor bronze spring clips, each clip in two sections.

With the band width control at the minimum setting or with the primary and secondary of the I.F. transformer farthest away, the selectivity with a signal 10 times the input is only 5.5 kc. and at 1,000 times the input only 11.5 kc. With the band width control at maximum width, actually at minimum selectivity, at 10 times the input, a 25 kc. band width is available.

The sensitivity is so great and receiver noise level so low that weak signal reception is limited only by the noise pickup of the antenna system. Real high fidelity is also available from this model, 50 to 10,000 cycles plus or minus 2 db, or minus 2 db. at 50 cycles and plus 1 db. at 10,000 cycles.

The image ratio at 14 megacycles is 1,600 to 1. At 1,000 kilocycles it is 316,000 to 1.

The receiver, which covers five ranges of from 2.5 to 5, 5 to 10 and 10 to 20 megacycles, and from 540 to 1,160 and 1,160 to 2,500 kilocycles, uses the following tubes—two 6K7 in two tuned r.f. stages; a 6J7 as local oscillator; a 6L7 first detector; three 6D6's in 465 kc. I.F. stages; a 6B7 as a combination fourth I.F. amplifier and diode second detector; a 6C6 low-frequency beat oscillator; a 6B7 for AVC; a 6C5 as a resistance-coupled audio-frequency amplifier; a 6F6 as a Class A driver; and two 6F6's operated as triode Class AB.

A Converter for Supers

Close Tracking Brings in Short Waves Splendidly

By Conrad L. Buckwall

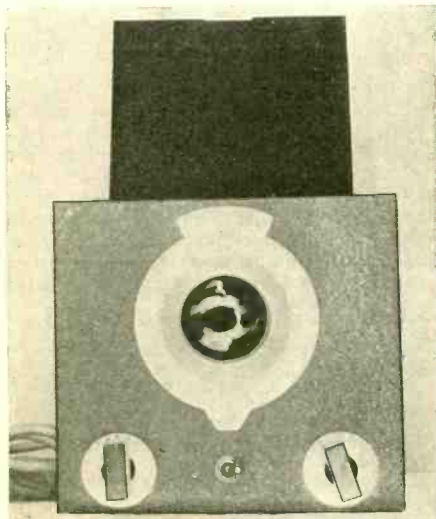

A cabinet regularly marketed by National Company is used for housing the short-wave converter.

A short-wave converter has been in use six years. During this time it has undergone several waves of popularity and disfavor. At present it is in the ascendancy. It is regaining some of the popularity it should never have lost. It is coming back into favor because it is sound in principle, for its principle is the same as that on which a superheterodyne works. This circuit is universally recognized as "tops." The converter, when worked with a suitable intermediate amplifier, should likewise be "tops." And it is, when designed as it should be for the job that it is supposed to perform.

A WORKING EXAMPLE

What are some of the necessary features? It should be self-contained. That is, it should have its own power supply, so that it does not have to depend for operating voltages on the receiver with which it is to be worked. It should have good radio-frequency selectivity, so that short-wave images will be eliminated. For the same reason the intermediate frequency should be high—the highest to which the broadcast receiver tunes. This not only helps to eliminate high-frequency images but it also makes

the converter practicable with a broadcast superheterodyne. The converter should be simple to tune and cover the entire short wave band.

The features enumerated above, and others, are incorporated in the short-wave converter shown in the diagram. It has a radio-frequency tuner for selecting the desired signal and rejecting others. This consists of a two-winding plug-in coil shunted by a variable condenser C_1 . This in turn is shunted by a trimmer C_2 . Since this tuner is placed between the open input circuit of the mixer tube and the low-load antenna, the selectivity gained is considerable. By low-load antenna is meant that the coupling between the tuned winding and the antenna is loose and that a comparatively short antenna should be used. If the antenna for the broadcast set is used, there should be a small condenser, say 50 mnfd., in series with it and the primary of the input transformer for best selectivity, though more volume may result without this condenser.

The oscillator tuner is similar to that of the radio frequency. It consists of a two-winding plug-in coil, the secondary of which is shunted by a variable condenser. This circuit is connected to the two innermost grids of a 6A8 tube in the usual oscillator manner. That is, the tickler is connected to grid No. 2 and the tuned circuit to grid No. 1. The stopping condenser is .0001 mfd. and the grid leak 50,000 ohms.

THE OSCILLATOR CAPACITIES

The oscillator condenser is complex and consists of four different condensers in series-parallel. A fixed padding condenser of .0005 mfd. is connected permanently in series with the variable tuning condenser C_s . This combination is shunted by two adjustable condensers, C_3 and C_4 , which are in series. By means of the three padding condensers and the shunt condenser in the radio frequency tuner, it is possible to adjust the circuit so that the tracking of the two tuned circuits, when tuned with the two-gang .00015 mfd. national variable, is good and within the adjustment range of the adjustable trimmer. Close tracking is essential for high sensitivity and freedom from interfering heterodynes, especially when the first circuit is highly selective.

The intermediate frequency for which this tuner has been designed and padded is 1,600 kc. Thus the broadcast receiver following the converter should be tuned to this frequency. It is not absolutely essential, however, to use this

frequency, and there may be reasons, such as whistles or local interference, why a slightly different frequency should be used. When it becomes necessary to avoid such trouble the broadcast receiver should be changed a little and then the converter returned.

R.F. CHOKE REQUIREMENT

The reason the intermediate frequency may be

RFC and a stopping condenser. The choke should have high inductance and small distributed capacity. This coupling is general in application and can be used with effectively with any type of input of the broadcast receiver. It will be noticed that the "hot" output lead is surrounded by a grounded sleeve. This ground prevents direct pick-up of broadcast signals having a frequency near the interme-

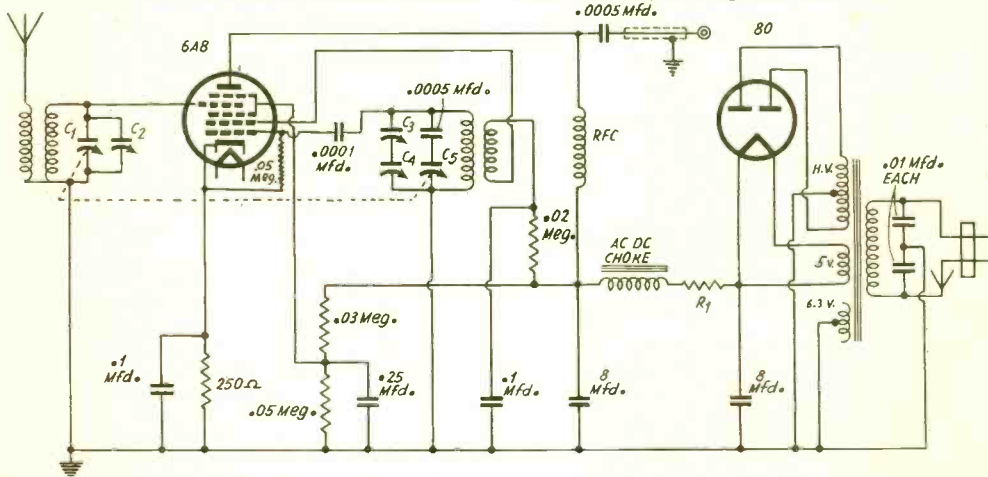

The circuit diagram of the converter that works well even on a super. It also produces results with a t.r.f. set, but with less sensitivity and selectivity.

changed is that there is no 1,600 kc tuner in the output of the mixer tube. The coupling between this tube and the input to the broadcast receiver is by means of a radio-frequency choke

intermediate frequency. This shielding of the "hot" output lead is of the utmost importance in localities where there are local stations operat-
(Continued on following page)

LIST OF PARTS

Coils

- Two sets of plug-in coils, four to a set, total eight coils, intended originally for .00014 mfd. t.r.f. sets.
- One radio-frequency choke coil, 2.5 millhenries, pie-wound.
- One a.c.-d.c. B supply choke.
- One small power transformer.

Condensers

- One two-gang National Co. tuning condenser, .00015 mfd. per section.
- One .0001 mfd. Two .01 mfd. One .25 mfd. Two 8 mfd. electrolytics.
- Two .0005 mfd. Two .1 mfd.
- Three trimmer condensers.

[Fixed condensers products of Cornell-Dubilier]

Resistors

- One 250-ohm ballast One .02 meg. One .03 meg. Two .05 meg.
- [Resistors products of International Resistance Co.]

Other Requirements

- One 80 socket (four prong).
- One seven-prong socket.
- One 80 and one 6A8 Sylvania tubes.
- One National Co. cabinet.
- One small grid clip.
- Two Isolantite sockets (four-prong)
- One line switch
- One National Co. vernier dial.
- Two control knobs.
- One steel box and chassis.
- One a.c. cable and plug.

(Continued from preceding page)
ing on or near any frequency that may be used for intermediate frequency. Conductor wire with a thick loom should be used, to reduce loss to ground, as the outer metal sheathing is grounded.

FILTER FUNCTION

It will be noticed also that there is a radio-frequency filter, consisting of two .01 mfd. condensers, across the primary of the input transformer. Its function is to prevent disturbing radio-frequency signals from entering the mixer by this route. It helps, therefore, to keep the output of the converter free from stray noises and interfering heterodynes. Sometimes the performance of a converter is unsatisfactory for no other reason than that it brings in too

WHITE SOCKETS ARE FOR COILS

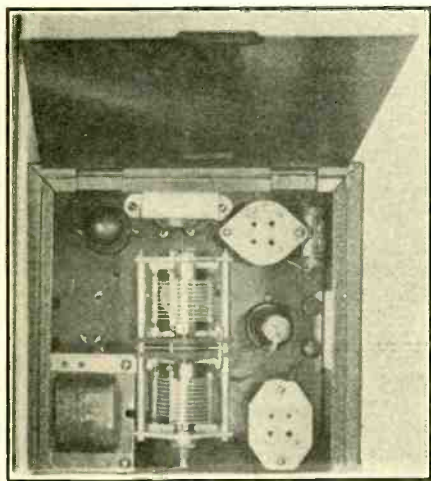

Arrangement of parts as seen through the top of the cabinet when the hinged lid is lifted.

much noise that could be excluded by a simple filter.

THE B SUPPLY

The B supply in this converter employs an 80 rectifier. It would seem that this is too large for a circuit that has only one tube to be served. The choice has been made for economical reasons—low first cost and maintenance. The output filter in the rectifier is typical of those used in a.c.-d.c. receivers. It has a small choke coil and two 8 mfd. electrolytic condensers. Because of the low current drain, this filter is many times more effective in the converter than it would be in a receiver of higher drain. But it is of utmost importance in a converter that the B supply be entirely free from ripple and noises. A converter is more sensitive to these disturbances than a receiver. Hence the thorough filtering is well advised.

There is a resistor R_1 in series with the filter choke. The purpose of this resistor is to drop some of the excess voltage, for it will be excessive, due to the low current drain, unless a special transformer is used. What the value of R_1 should be depends mainly on the output voltage of the power transformer and is subject to variation. The voltage applied to the anode of the oscillator is lowered still further by a .02 megohm resistor in the lead. A condenser of .1 mfd. is used here to prevent the oscillation currents from entering the B supply and to make the circuit oscillate more readily. The screen voltage for the tube is obtained from a voltage divider across the output of the filter. This divider consists of one .03 meg. resistor on the high voltage side and a .05 megohm resistor on the ground side. A by-pass condenser of .25 mfd. serves to keep the screen voltage steady.

LAYOUT AND HOUSING

The grid bias for the mixer tube is provided by a 250-ohm resistor in the cathode lead, shunted by a condenser of .1 mfd. The bias is essential for greatest conversion efficiency and highest radio frequency selectivity.

The arrangement of the various parts is shown in the top view photograph. The two-gang national condenser is in the center, the power transformer in the left front corner, and the filter choke at the rear behind the condensers. The two coil sockets occupy the two corners at the right and the mixer tube is half way between them. The rectifier is in the left rear corner. Two trimmer condensers, for which the controls are on the panel, are below the chassis and for that reason are not visible in the top view photograph. This view shows the converter in a metal box with the lid open. When this lid is closed, the parts are completely shielded. The output leads, which are connected to the two binding posts seen to the right of the mixer tube, are shielded outside, as has already been pointed out.

GIVES ENTIRE SATISFACTION

The front view photograph gives an idea of the vertical arrangement of the principal parts. The vernier dial, which controls the two-gang condenser, is located in the center of that space which is above the sub-panel. The two knobs shown at the lower corners control the trimmer condensers. These controlled trimmers are indicated by C_2 and C_3 in the circuit diagram. The line switch is conveniently located centrally just below the tuning dial.

This short wave converter has been operated with entire satisfaction both with broadcast superheterodynes and tuned radio frequency receivers. Some of the reasons why it has proved satisfactory are that the converter and its output lead have been thoroughly shielded, that provision has been made for precise tuning, that the device is self-contained, and that it covers the entire short wave band by means of standard plug-in coils. As intended for t.r.f. .00014 mfd. tuning, e.g., coils are equal for a given band.

RADIO CONSTRUCTION UNIVERSITY

Answers to Questions on the Building and Servicing of Radio and Allied Devices.

POSITIVE Mu OSCILLATOR

PLEASE show one of those positive mu oscillators, as you call them, rigged up for universal operation, not necessarily to include modulation, as I test by the unmodulated method. Show an attenuator.—U. R.

The diagram herewith gives the circuit and the constants. The inductances are selected in respect to the condenser capacity and the bands to be covered. Normally a device such as shown, starting with about 20 millihenries, will cover from 50 kc to 20 mc with .000365 mfd. It is sometimes difficult, however, to get this type of oscillator to oscillate at much higher than 15 mc, but the high screen load resistor is in the right direction, yet may be increased in value as an attempt to press oscillation to higher frequencies, if that is imperative.

* * *

BYPASS CONDENSER

WHAT is the need of a bypass condenser across the cathode biasing resistor of a dual-purpose tube, comprising, say, two equal

triodes in a single envelope?—I. F.

Such a condenser is advisable, even though the phases of the signal current through the resistor are opposite, because the magnitudes of the currents are unequal.

* * *

OUTPUT TERMS

WHAT is the difference between the power output capability and the power sensitivity? I thought they were the same thing, but I have seen tabulations that indicate to the contrary.—L. W.

The power output is a rating of the output capability at a stated percentage distortion, and measures the amount of work that can be done by the output circuit, when the input is loaded to its allowable limit. The power sensitivity is the ratio of the output power to the input power required to establish that rated output. Therefore the tubes that require little input to accomplish large output have a much higher power sensitivity rating, although the actual output power may be the same.

(Continued on following page)

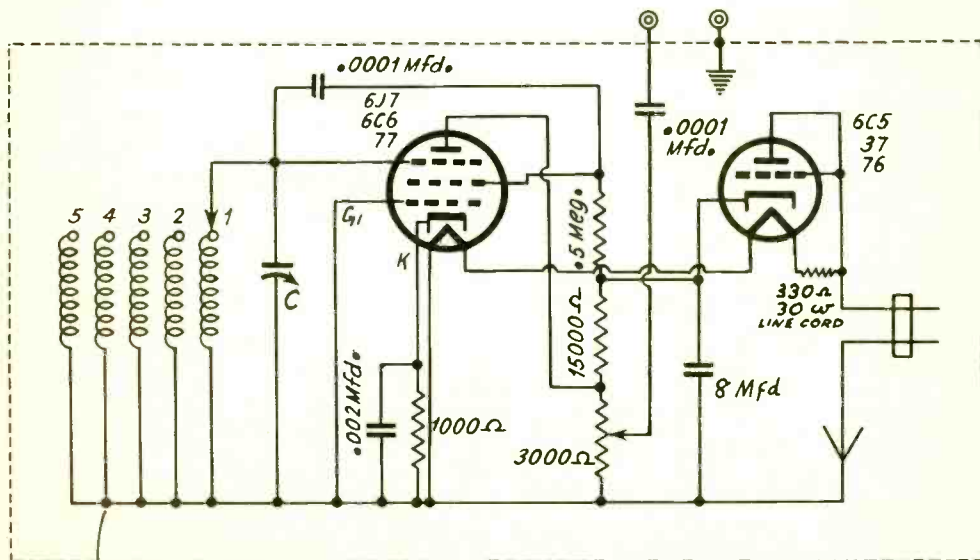

INSULATE FROM CHASSIS

Positive mu test oscillator.

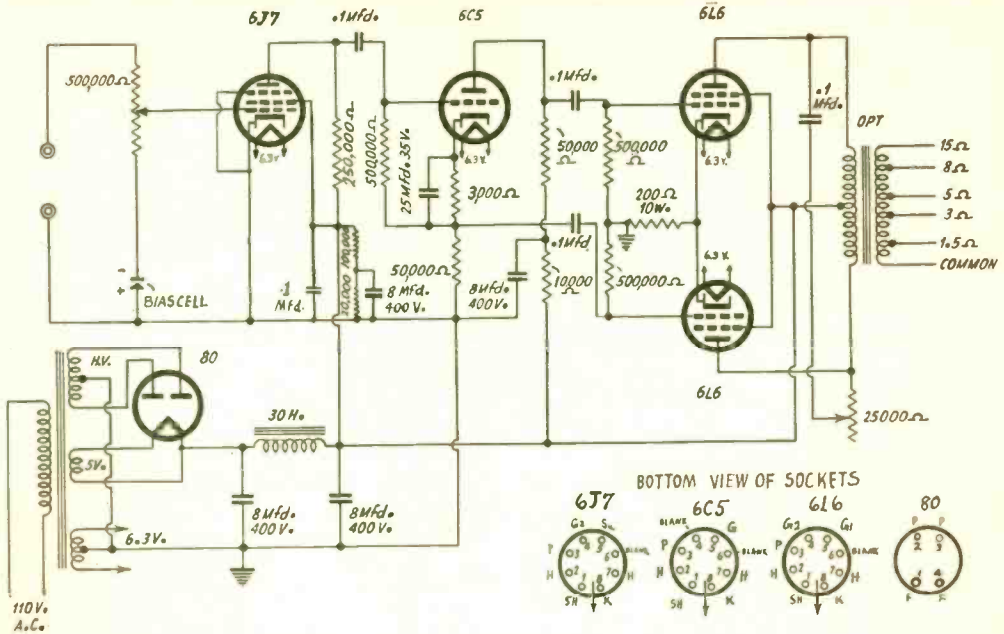

There is a mistake in this diagram and it should be possible for any one fairly familiar with radio technique to spot the mistake in not more than six minutes. See question from V. C. S. on which the diagram is based. Answer appears at the foot of the page.

WHAT'S WRONG HERE?

SOMEBODY told me that it is a good test of radio knowledge to be able to find mistakes quickly in a diagram. If so, could you give me an example, and a time limit? Your problem would be based on the fact I have read technical radio rather closely for two years, although I am engaged in an entirely different line of business.—K. C. S.

Having spent spare time during two years in reading up on radio you should have sufficient knowledge to be able to spot the mistake in the diagram herewith in not more than six minutes. If you had had two more years' experience the time would be reduced to three minutes. So see what you can do, knowing in advance that there is only one mistake. After you think you have spotted the mistake, check against the correct answer at the foot of this page.

PHOTO-ELECTRICITY OF TUBES

CAN regular radio tubes be used to attain a photo-electric effect? I desire to make some experiments, but at first would desire to avoid the expense of the usual cells. Please state what tube to use.—J. E. D.

It is practical to use some glass tubes for the photo-electric effect. In general, the tube is operated at lower than rated filament voltage, and at a low plate voltage. Then the current is read on a series meter in the plate circuit.

When light is directed at the glass envelope, especially from a critical angle, a considerable change in plate current will take place. This demonstrates the photo-electric effect. It is due partly to the magnesium used as getter, to clear away foreign gases, in the tube, serving photo-electrically, e.g. in the 45 tube. Hence it is assumed that tubes with a generous coating of the silver-like substance on the inside of the glass envelope are to be preferred.

WHAT'S WRONG

The screen voltage on the 6J7 in the diagram on this page is the same as the plate voltage, and the rating of the electrolytic at the end of the B filter is such as to indicate that the screen voltage therefore is too high. A bleeder circuit consisting of two resistors of 20,000 and 100,000 ohms each, with bypass capacity from tar to B minus, serves no purpose. Therefore, disconnect the screen from its present return, and connect it instead to the juncture of these two resistors. Then the .1 mfd. condenser from screen to ground becomes superfluous and may be removed. This explanation refers to a question by K. C. S. on this page.

TRADIOGRAMS *of the* MONTH

Triplett VTVM Self-Calibrating

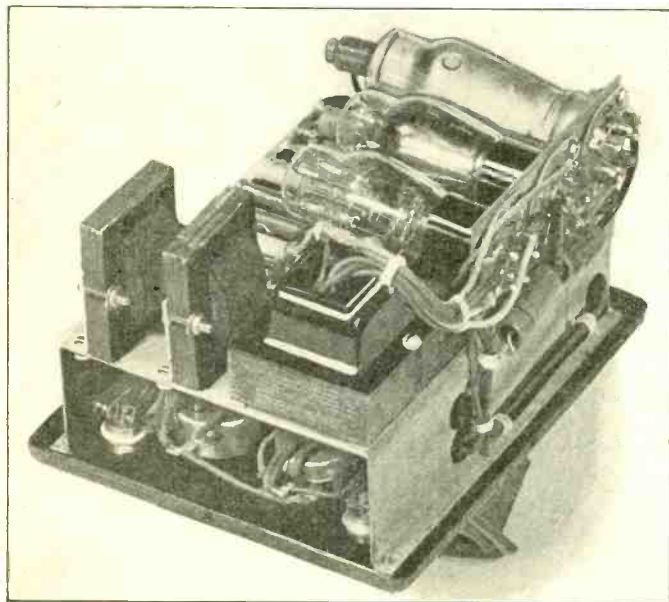

Triplett Electrical Instrument Company, Bluffton, Ohio, has announced a self-calibrating vacuum tube voltmeter, Model 1250, illustrated herewith. It measures low a.c. and d.c. voltages without current drain. A new bridge circuit is used whereby tube characteristics are stabilized, regardless of tube emission. All that is required is to balance the bridge and then read the unknown voltage directly. Ranges are 2.5, 10 and 50 volts, all in the one instrument.

Steinle Back with Triad As Director of Sales

George Coby, president of Triad Manufacturing Co., Inc., of Pawtucket, R. I., announced that Harry H. Steinle has again joined the organization as vice-president and director of sales.

Mr. Steinle was general sales manager of Ceco Mfg. Co. until shortly after the sale of the Ceco Mfg. Co. to other interests, when Mr. Steinle assisted Mr. Coby and his associates in the organizing of the Triad Mfg. Co., Inc. as vice-president in charge of sales. Under Mr. Steinle's guidance Triad Radio Tubes quickly gained national distribution.

About three years ago, Mr. Steinle joined the organization of Arthur H. Lynch, Inc.

Lynch and Brach Unite

The Lynch Division of the L. S. Brach Manufacturing Corporation, 55 Dickerson Street, Newark, N. J., has been formed under Arthur H. Lynch. The sale of Lynch products will be continued under the management. The consolidation is for the marketing of antenna systems and kindred devices, including some new ones to be announced soon.

Adelman Reports Vast Sales Gain of C-D

One of the best customers of the commercial airlines is Leon L. Adelman, sales manager of Cornell-Dubilier Corporation, South Plainfield, N. J. During the last few months, however, the flying personnel of TWA, United Airlines and American Airlines have missed Leon's smiling features. Result—personal cards from pilot pals.

Leon has been practically tied to his desk for more than 90 days, and has been forced to resort to the long-distance telephone. With both New York and Plainfield plants of the Cornell-Dubilier Corporation operating at full capacity, the production of C-D condensers has reached 60% above the peak of 1935, and with orders pouring in at an unprecedented rate, bids fair to make twenty-four hour shifts necessary.

The 1934 sales doubled the 1933 sales record; the 1935 figures quadrupled the 1933 figures, and at the present rate of increase will show a clear gain of 60% over the 1935 sales.

This figure, says C-D, is an all-time high for the production of condensers in the entire radio industry.

Choke-Input Rectifier Filter

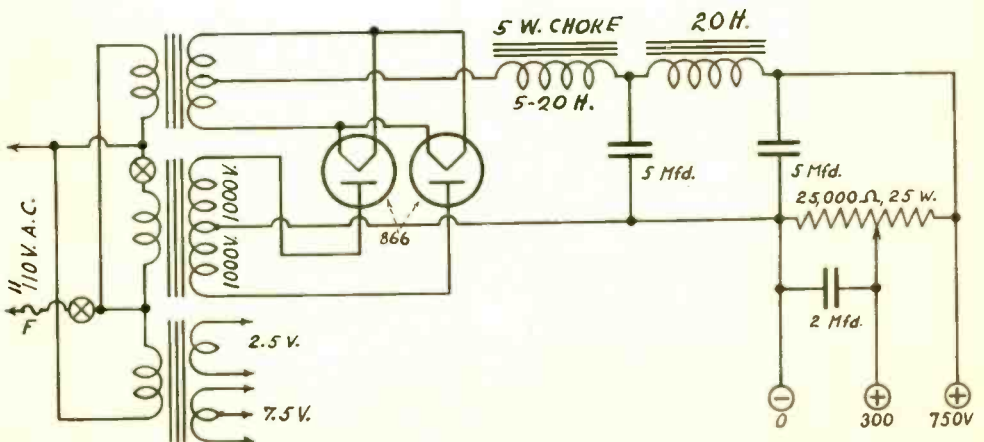
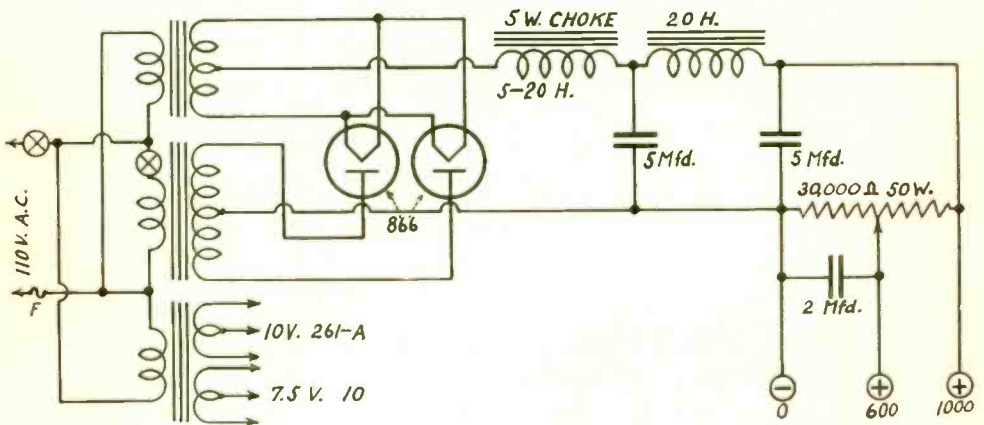
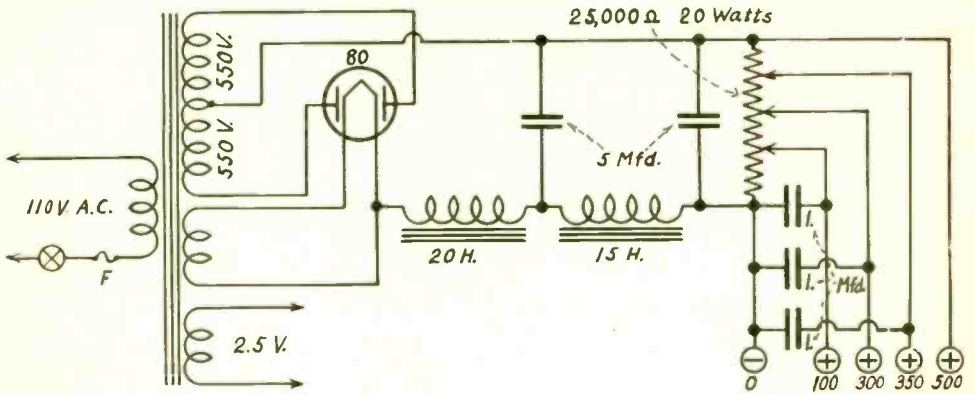

Top, for transmitter oscillator; center, for modulator; bottom, for "final."

You need these 2 books

PRINCIPLES of PUBLIC ADDRESS SYSTEMS

A practical handbook, full of useful information, fully illustrated, written by M. N. Beitman, an engineer and noted authority on audio amplifiers.

Considers in detail various microphones, radio and phonograph inputs, acoustic feedback, mixing and volume controls, use of vacuum tubes, interstage coupling, power amplifiers, output coupling, loud speaker placement, the decibel, P.A. measurements, power level, and other points of importance, including actual circuit diagrams of tested P.A. systems.

MATHEMATICS of Radio Servicing

Introduces and explains the use of arithmetic and elementary algebra in connection with units, color code, meter scales, Ohm's Law, alternating currents, ohmmeter testing, wattage rating, series and parallel connections, capacity, inductance, mixed circuits, vacuum tubes, curves, the decibel, etc., etc. and has numerous examples.

Plainly written and easy to understand. Only useful data included. M. N. Beitman, author. Size, 8 1/2 x 11 in.

Price, 50c each book.

SUPREME PUBLICATIONS

3727 West 13th St., Chicago, Illinois

MAILING LISTS

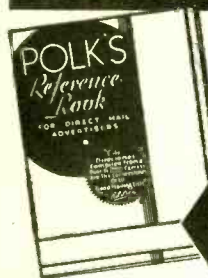

GET OUR FREE REFERENCE BOOK and MAILING LIST CATALOG FREE

Gives counts and prices on accurate guaranteed mailing lists of all classes of business enterprises in the U. S. Wholesalers—Retailers—Manufacturers by classification and state. Also hundreds of selections of individuals such as professional men, auto owners, income lists, etc.

Write today for your copy

R. L. POLK & CO.

Polk Bldg.—Detroit, Mich. Branches in Principal Cities

World's Largest City Directory Publishers Mailing List Compilers. Business Statistics. Producers of Direct Mail Advertising.

CLASSIFIED ADVERTISEMENTS

7 cents a word. \$1.00 minimum.

AMATEUR RADIO LICENSES. Resident and correspondence courses. Every graduate a licensed operator. New York Wireless School, 1123 Broadway, New York.

AMATEUR SNAPSHOTS WANTED IMMEDIATELY! Thousands demanded by publishers. Earn cash supplying them. Stamp brings details. International Photos, Division 187, Hohm Building, Western and Sixth, Hollywood, California.

AMATEUR CARTOONISTS—Win \$25. No drawing ability necessary to win. 26 prizes in all. Rush name on postcard for valuable tips on "How to Make Money with Simple Cartoons." Cash Prize. Entry Blank and Rules. Send no money. Cartoonists' Exchange, Dept. 1451, Pleasant Hill, Ohio.

\$50. A WEEK WITH A KODAK: Booklet describing 100 Magazine Markets, 25 cents, postpaid. Hammons, Box 265, Corbin, Kentucky.

CAMERAS AND SUPPLIES. Free illustrated catalog listing everything photographic—still and movie cameras, films, lenses—at tremendous savings. Thousands of bargains, new and used. All guaranteed. We take your old camera or equipment in trade. Write now for your free copy of our Photographic Almanac and Bargain Book—just out! Limited edition. Hurry! Central Camera Co., (Photographic Headquarters since 1899), 230 So. Wabash, Dept. RW-137, Chicago.

SPECIAL 2-FOR-1 OFFER RADIO WORLD

Radio World is \$2.50 a year (12 issues), 25c. per copy. Canada and foreign, \$3.00 yearly. Offers of Radio World and other worthwhile publications for one full year on each (NET):

- RADIO WORLD and SHORT-WAVE CRAFT, \$3.50.
- RADIO WORLD and POPULAR SCIENCE MONTHLY, \$3.50.
- RADIO WORLD and RADIO-CRAFT (12 issues), \$3.50.
- RADIO WORLD and RADIO INDEX (monthly, 10 issues), stations, programs, etc., \$3.50.
- RADIO WORLD and SERVICE (monthly), \$3.50.
- RADIO WORLD and EVERYDAY SCIENCE AND MECHANICS (monthly), \$3.50.
- RADIO WORLD and BOYS' LIFE (monthly, 12 issues), \$3.50.
- RADIO WORLD and MOTION PICTURE MAGAZINE (monthly), \$3.50.
- RADIO WORLD and TRUE STORY (monthly), \$3.00.
- RADIO WORLD and LIBERTY (weekly), \$3.00, U. S. only.

Select any one of these magazines and get for an entire year by sending in a year's subscription for RADIO WORLD at the regular price, \$2.50, plus a small additional amount, per quotations above. (Add \$1.50 for extra foreign or Canadian postage for both publications.)

Name
Address
City and State.....

- If renewing an existing or expiring subscription for RADIO WORLD, put cross in square.
- If renewing an existing or expiring subscription for other magazines, put cross in square.

Special Trial Offer for Radio World only: \$1.00 for 5 months, postpaid. Mail order with remittance to Radio World Office. NET.

Literature Wanted

Readers whose names and addresses are printed herewith desire trade literature on parts and apparatus for use in radio construction. Readers desiring their names and addresses listed should send their request on postcard or in letter to Literature Editor, Radio World, 145 West Forty-fifth Street, New York, N. Y.

Charles Bernstein, 466 Sheffield Ave., Brooklyn, N. Y.
—Catalogs.

Thomas P. King, 280 Martense St., Brooklyn, N. Y.
Mono Radio Laboratory, R. C. Moninghoff, Durham Road, Riegelsville, Penna.—radio dials, cabinets, and both variable and fixed condensers.

Bernarr, C. George, 22 King Edward Road, 1, Oxhey, Watford, Herts, England—switches for meters and S.W. (all wave) crystal filters, and S.W. parts generally.

R. W. Winget, Garden City, Kans.
Richard R. Heilman, 35 Canal St., Lebanon, Penna.
H. J. Thompson, 1202 Cook Ave., Cleveland, Ohio.

Jack D. Stevenson, 9 N. E. Holladay St., Portland, Oregon.

General Radio Service, Bert Glase, Manager, Bantavia-C, N.O.I., Netherlands East Indies.

K. R. Zumhagen, 1009 W. Center St., Milwaukee, Wisc.—used and for sale test equipment, also in kit form or ready made, chassis, and sound equipment, with diagrams and specifications on how to build service equipment.

C. S. Brown, 206 Film Bldg., Cleveland, Ohio.
Joseph Gigliotti, 311 Main St., Boonton, N. J.

Herman Heltzel, Wardensville, West Va.
Ray Harriggfield, Emerson, Nebr.

D. Kienzie, 4916 Chestnut St., Philadelphia, Pa.
M. Glaser, 2916 Brighton 7th, Brooklyn, N. Y.

George J. Lauz, 614 Greendale Ave., Swissvale, Penna.
George Rohr, 67 Thorne St., Jersey City, N. J.

Herbert Etzel, R. No. 2, Pewaukee, Wisc.
George Makuhm, 2095 W. 15th St., Cleveland, Ohio.

A. Flicker, c/o Jetka Hardware, Little Falls, Minn.
Sidney Block, 859 Freeman St., Bronx, New York City.

S. Gould, 4508 N. 18th St., Philadelphia, Pa.
C. W. Reash, 9 News St., Greenville, Penna.

Joseph Wunderlich, 802 E. Webster, Clinton, Ill.
Andrew Ferencz, Monessen, Penna.

Joseph S. Papora, Uniontown, Penna.
Floyd Scripture, Sheridan, Ind.

D. E. Straube, Schoolcraft, Mich.
Jerry Clifford, West Los Angeles, Calif.

A. N. Hugner, Cheviot, Ohio.

HAVE YOU BACK NUMBERS of Radio World, August, 1935, or June, 1936, issues? If so, please communicate with Radio World, 145 West 45th Street, New York, N. Y.

A Birthday Gift for HIM

Is your husband, son or nephew interested in radio? Why not send him RADIO WORLD for the coming year? We will send him, at your request, a letter so that he will receive it the day before his birthday telling him of your generosity and thoughtfulness. For \$2.50 a year in the United States he will be reminded of your unselfishness every time the magazine arrives. RADIO WORLD, 145 West 45th St., New York, N. Y.

METAL CHASSIS

We can supply chassis for any make receiver, experimental or otherwise.

Inquiries should be accompanied with sketch and complete details enabling us to give quick service as to prices and delivery.

KORROL MFG. CO., Inc.

232 Greenwich St. Dept. RW-137 N. Y. City

The EXPERIMENTERS TREASURE HOUSE

Since 1923, we have been catering to the needs of Radio and Electrical Experimenters. From cat-whisker to television tubes, miniature motors, relays from 29c to \$6.50—photoelectric cells, neon lamps from 15c to \$1.50, in fact anything and everything you may need, in stock or know where to obtain for you. We have been shopping agents for well-known schools and institutions for many years, why not for you?

Headquarters for Parts—Since 1923

BLAN

THE RADIO MAN, INC.

W-177 Greenwich St., New York, N. Y.

NO CATALOGUE—BUT LOWEST PRICES

WALLY'S

Largest dealer service in the city.
Cracker-jacks on tough installations and motor noise elimination.

(Authorized All Makes)

AUTOMOTIVE AND MARINE SPECIALISTS
HUDSON TERMINAL GARAGE BLDG.

WOrth 2-9080 WOrth 2-3131
61 Dey Street, 1 block south Fulton St., New York City

BETTER SELECTIVITY with Iron-Core I.F.'s

USERS of our iron-core intermediate-frequency transformers are delighted with the increased selectivity, also the improved gain.

We also have tuner coils, for t.r.f. sets and supers using two-gang to four-gang .000365 mfd. condensers. We do not have tuner coils for 140 mmfd. condensers. Our tuner coils are of the shielded or unshielded types, as preferred. For two-gang sets the unshielded type give better results. For three- or four-gang sets the shielded type are necessary. Either type obtainable in high-gain or low-gain models.

Iron-core, doubly-tuned i.f. transformers, 175, 456 or 465 kc (specify which).....\$1.15

High-gain r.f. coils, for .000365 mfd., for two-gang t.r.f. set, unshielded, 90¢ a pair.

High-gain r.f. coils for three-gang t.r.f. set, shielded.....\$1.80 for three.

Low-gain r.f. coils for four-gang t.r.f. set, shielded.....\$2.40 for four.

Local oscillator coil, shielded, for 175, 456 or 465 kc.....60¢

Local oscillator coil, unshielded, 456 or 465 kc, only.....45¢

Set of matched shielded coils for three-gang super (specify i.f.).....\$1.80

Set of matched shielded coils for four-gang super (specify i.f.).....\$2.40

8 millihenry honeycomb r.f. choke.....40¢

One-to-one transformer, two 8 millihenry windings loosely-coupled, in shield.....\$1.00

Coils are on hand for all circuits using .000365 mmfd. for tuning. State your requirements.

Padding condenser for 465 or 456 kc.....50¢

Padding condenser for 175 kc.....55¢

All the above prices are postpaid.

SEND FOR FREE CIRCUIT DIAGRAMS, T.R.F. AND SUPERS
RADIO DESIGN CO.

Dept. R-1236

1353 Sterling Place Brooklyn, N. Y.

THOR'S AFTER CHRISTMAS SPECIALS

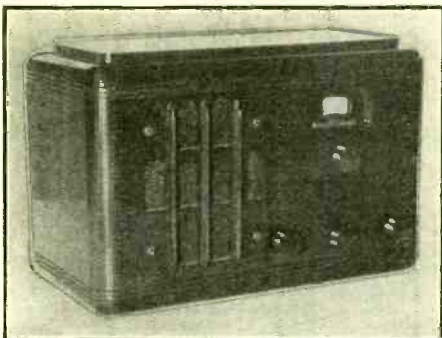

1937 General Electric No. A-54, 2 Band Superheterodyne, 5 metal tubes. Operates on either AC or DC current. Full 1 watt output \$19.95.

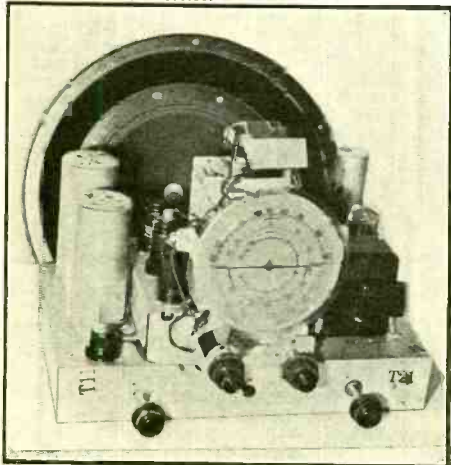

American Bosch No. 585Z All Wave Superheterodyne, with patented centromatic tuning, and shadowgraph tuning. Sold only in chassis form, complete with speaker and tubes, limited quantities \$27.50.



Atwater-Kent, 7-tube, battery-operated 3-Band Superheterodyne for 2-volt battery supply. \$24.50.

A compact, well-built set with tremendous sensitivity and hairline selectivity. Rich and mellow in tone powered by 6½-inch dynamic speaker and incorporating music and speech tone control.

Circuit is conventional superheterodyne with automatic volume control and overload control.

Tunes full amateur, police, aviation and foreign band through to 49 meters. Wave coverage 1700 to 550 K.C. on broadcast, and 1700 to 6000 K.C. on short wave. Beautiful butt walnut cabinet, hand rubbed, size 14 inches long, 9½ inches wide, 8 inches deep. Shipping weight 16 lbs. Complete with 5 RCA metal tubes. Guaranteed one full year. **\$19.95**

A genuine American Bosch product offered in chassis form. Ideal for mounting in cabinets, fireplaces or odd pieces. A powerful 8-tube Superheterodyne built around the Bosch Centromatic tuning unit completely shielded and rubber cushioned. Four full bands covers all wavelengths from 15 to 2000 meters. Full vision 5-inch airplane dial with 2 speed drive and split second hand. Tone control and large 14" dynamic speaker contribute to marvelous tone. Circuit incorporates a stage of pre-selection, 2 stages of intermediate frequency, automatic volume control and Pentode output of 4 watts. Equipped with 7 RCA meter and 1 RCA glass tube. Shadowgraph tuning permits exact station allocation. Size, 14" long, 8½" deep, 11½" high. Shipping weight, 28 lbs. Complete with 14" dynamic speaker and 8 genuine **\$27.50** RCA glass tubes. Guaranteed 1 full year.

7-tube 3-band Superheterodyne with selective band switchings showing an illuminated dial. Covers full foreign, amateur and broadcast band from 15 to 600 meters. 2 speed tuning tone control and automatic volume control. Uses new low drain 2-volt tubes exceptionally economical on batteries. Requires one "A" battery of 2 volts, three "B" batteries of 135 volts. Makes an ideal set for farms, camps and boats. Push-pull audio and preselection on all hands. Size, 13½" wide, 18" high, 8½" deep. Shipping weight. Complete with set of RCA tubes less batteries **\$24.50**

6-volt model requires no "B's"..... **\$26.50**

ASSORTED SPECIALS

Grunow 110-volt 60-cycle phono motors, speed control, self-starting 12" turntable **\$4.95**

Walco high-impedance magnetic pickup, lightweight, good reproduction.. **\$2.95**

Astatic Crystal pickup, finest of all pickups. High-impedance **\$5.99**

General Electric all-wave 1937 aerial kits. Complete with all wire and transformer. Fits any and all sets..... **\$3.19**

Mail orders filled, 24-hour service.

Order from this ad. All merchandise guaranteed.

THOR RADIO, 65 CORTLAND STREET, NEW YORK CITY

Expertly Selected Radio Books

Best Calculated to Advance Your Knowledge and Expedite Your Operative Technique

Undisputed Leader of All Radio Service Books



Alfred A. Ghirardi's "Modern Radio Servicing" is the standard book in the field. It contains everything you need to know about radio servicing as it is practiced today by the most successful organizations in the country. All about test instruments, their theory, operation and construction, complete with circuit diagrams. All the latest test and repair methods and trouble-shooting short-cuts. All the most successful repair methods. Big sections on noise and interference "spotting" and elimination in broadcast and all-wave sets; on aligning receivers (including cathode-ray method); AVC and QAVC circuits; auto radio; sales and advertising; etc. More than 1,300 pages. 749 illustrations. Order Cat. MRS, postpaid, \$4.00.

Ghirardi's "Radio Field Service Data," new edition, has more than 400 pages of practical "bench data"—twice as much as the first edition. I.F. peaks for 5,226 superhets, including 1937 models. "Case Histories" for over 1,500 receivers, giving actual trouble symptoms and remedies for each one. Ignition system data, interference remedies, and electrical wiring diagrams for all cars. Latest data on glass and metal tubes. In all, more than 70 different charts, diagrams and tables arranged in handy form for quick reference. Now in loose-leaf form, it is easily kept up to date with the Supplements issued every January and June. Order Cat. RFS, postpaid, \$2.50 (includes supplements for one year).

Combination price of \$6 gives you both these indispensable servicing books, together with one year's supplements to the Data Book. Order Cat. COMRFS.

Other Top Selections

"THE INDUCTANCE AUTHORITY," by Edward M. Shiepe. Enables winding radio-frequency solenoids to 1% accuracy without computation. Order Cat. INA @ \$2.00, postpaid. Price includes 18x20" inductance-capacity-frequency chart as supplement.

"MEASUREMENTS IN RADIO ENGINEERING," by Frederick Emmons Terman, revealing the measurement equipment and technique, from the pen of a great authority. 400 pages, 6x9. 208 illustrations. Order Cat. TMRE, postpaid, \$4.00.

"PRACTICAL RADIO COMMUNICATION," by Arthur R. Nilson and J. L. Hornung, a complete instruction course and reference guide in radio station operation. Principles, systems, equipment, operation (including short and ultra waves). 754 pages, 6x9; 435 illustrations; flexible cover. Order NHPRC, postpaid, \$5.00.

The Handiest Handbook of All!

A handbook is handy when it "has what it takes," is expertly referenced, and quickly provides authoritative solutions. This Keith Henney's "Radio Engineering Handbook" certainly does. It's a great book for engineer or experimenter. Really 24 reference books under one cover. 850 pages, 4½x7. Fully illustrated. Flexible cover. Order Cat. HREH, postpaid, @ \$5.00. New edition.

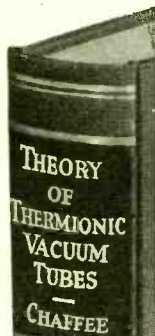

The Tube Authority

A fundamental treatise, comprehensive and authoritative. "Theory of Thermionic Vacuum Tubes," by E. Leon Chaffee, Professor of Physics, Harvard University, covers the field. A knowledge of algebra and some calculus are necessary for full appreciation of the contents. Treatment is mathematical. 652 pages, 6x9; 357 illustrations. Order Cat. CTTVT, postpaid, @ \$6.00.

Any or All of Above Books Sold on Five-Day Money-Back Guarantee!
BOOK DEPARTMENT, RADIO WORLD, 145 W. 45th ST., N. Y. C.

THE NEW R-S-R CLIPPER

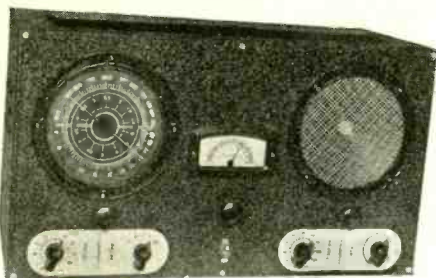

Tomorrow's Set Today

Designed by A. J. HAYNES

whose original R-S-R receiver was featured last Spring in the leading radio publications as the first commercial radio receiver to combine the new ultra-high frequency bands with all-wave foreign and domestic broadcast reception. We are exclusive builders of the new R-S-R CLIPPER communication receiver.

HERE ARE A FEW FEATURES WHICH CONTRIBUTE TO THE CLIPPER'S OUTSTANDING PERFORMANCE

*Seven separate tuning bands.

*Tuning range from below 5 meters to 550 meters; covers every foreign and domestic short wave broadcast and amateur band as well as airplanes, police, television, ship-to-shore and inter-continental radiophone, and brings them in on the speaker as loud as you want them.

*6L6 Beam Power tube output and 6" dynamic speaker.

*A. C. Power supply built in with high voltage transformer.

*R.F. amplification on all bands including 5 meter. Accurately calibrated dial and band switching (no plug-in coils) from top of broadcast band down to 22 megacycles.

*Isolantite insulated three plate condenser with vernier drive dial is used for both bandsread and ultra-high frequency tuning.

*Combined regeneration and super-regeneration using five tubes at all times including 2 new 6J5G super-triodes and 6K7 metal tube R.F. amplifier.

*Tone control, standby switch, earphone jack, etc. In short the new R-S-R CLIPPER incorporates every worthwhile feature the experimenter could wish for in his personal receiver. PRICE complete with 5 Sylvania tubes ready to operate..... **\$28.85**

NEW THE AC-4 Communication Receiver

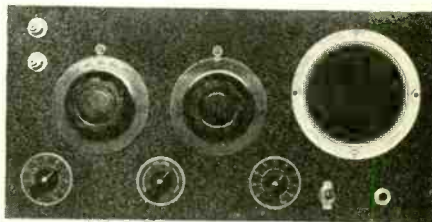

An outstanding achievement. A truly fine regenerative receiver covering the tremendous tuning range of 2½ to 555 meters. A.C. operation with built-in power supply. Isolantite insulated handsread and high-frequency tuning condenser. Super-regeneration on the 5 and 10 meter bands. Separate volume and regeneration control. Antenna coupling control on front of panel. Straight-line-frequency tank condenser. Jack for earphones, cuts out speaker. Standby switch, etc. Uses three of the new 6J5G super-triodes with 80 rectifier. The AC-4 stands in a class by itself among long distance low price receivers. It is the greatest "miles per dollar" value in radio; a real communication receiver with perfect bandsread—the 20 meter amateur band, for instance, one of the most fascinating DX bands which is only 400 kilocycles wide, covers 100 degrees on the big 3½" German silver bandsread dial with NO band capacity effect. On foreign reception you will be amazed at the way the AC-4 separates the crowded foreign stations on the short-wave bands. Price, AC-4; complete kit of parts, drilled chassis, speaker, etc. Less only cabinet and tubes..... **\$10.75**

Crystalline finished metal cabinet..... \$1.25
 Kit of four picked Sylvania tubes..... 2.05
 Wiring and testing 2.50

SPECIAL PRICE ON COMPLETE AC-4;
 wired, tested and ready to operate **\$15.85**
 from any 110-volt line.....

RADIO CONSTRUCTORS LABORATORIES

Dept. WRI

136 Liberty St., New York

A REAL SIGNAL GENERATOR

Covers 100 kc. to 22 mc., with modulation present or absent on all bands by switching—Also tests filter condenser leakage. Price, Complete with three tubes. (Shipping weight, 7 lbs.) Model T-37.....

\$12.40



EVERY service man and experimenter appreciates the necessity of using a signal generator for aligning i.f. and r.f. levels. Here is an opportunity to possess one that covers wide range by front-panel coil-switching and is equipped with attenuator. Thus sets with a.v.c. can be aligned properly. All generation is on fundamentals. No harmonics are used.

NOTE THESE FINE ADVANTAGES!

FASTEST-SELLING among signal generators, this device has earned its laurels because it provides:

1. Operation on 90-120 volts. 110 Volts A.C. or D.C. and if A.C., any commercial frequency.
2. 110 kc.—22 megacycles, all on fundamentals.
3. Front panel switch selection of five bands.
4. Modulation present or absent by front panel switching.
5. Dial is direct reading in frequencies.
6. R.F. output may be taken from a high impedance or a low impedance post, with attenuation Present or absent for either.
7. Separate audio output at two amplitude levels, so that tone may be used for checking public address systems, audio amplifiers in receivers, and speech amplifiers in transmitters.
8. Two extra posts on front panel enables filter condenser leakage tests. Condensers may be checked, so may tubes, and other normally high resistance circuits, otherwise difficult to test.

CONDENSER ANALYZER

DIRECT-READING in capacity up to 16 mmfd., this condenser analyzer gives true readings of capacity, also tests leakage accurately and serves besides as output meter.

Tells Everything You Want to Know About a Condenser

Is it shorted or open circuited?
Does it leak and how badly?
What is its capacity?

By throwing a switch you have a sensitive output meter with shunt voltage adjustment for use with your oscillator when lining up receivers.

Three instruments that are indispensable to every serviceman combined in one small portable case and operating directly from the 110 volt A.C. line.

Model 40 Capacity Analyzer, in shielded cabinet with carrying handle, wired, calibrated and tested; complete with 2 tubes. (Shipping weight, 7 lbs.)

\$7.40

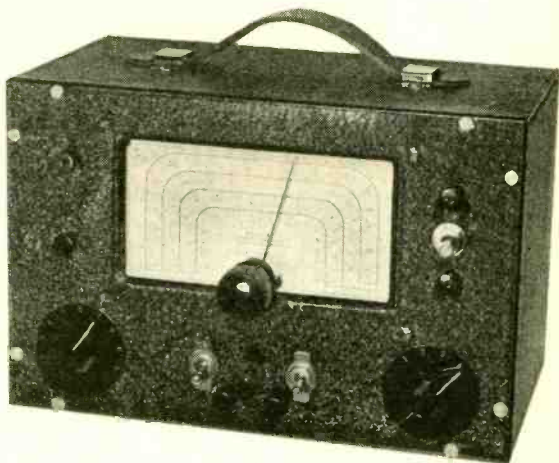

SUPERIOR INSTRUMENTS COMPANY

Dept. 102, 139 Cedar Street

New York, N. Y.

The
new
edition

NATIONAL



RADIO PRODUCTS

DESCRIPTIVE
PRICE LIST

260
BULLETIN NO.

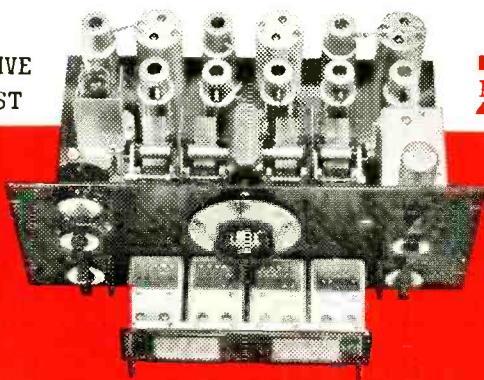

NATIONAL COMPANY INCORPORATED
61 SHERMAN STREET • MALDEN, MASSACHUSETTS

Engineers and Manufacturers

ESTABLISHED 1916

If you are without a copy of the new National General Catalog, write us and we will gladly send you one. Or better, visit your dealer. He will welcome the opportunity to give you a copy of this new catalog and to demonstrate the latest National products.

NATIONAL COMPANY, INC., MALDEN, MASS.

TRIPLET Pocket Volt-Ohm Milliammeter D.C. and A.C.

Size:
3 1/16" x 57/8" x 2/8"



MODEL 666

DEALER PRICE **\$15.00**

A complete instrument for all servicing needs. Can be used for all AC-DC voltage, current and resistance analyses.

LEATHER CARRYING CASE—Model 669, supplied extra.
Very attractive. Of black, heavy leather with finished edges and strap.

- Uses Large 3" Sq. Triplet Instrument. AC-DC Voltage Scales Read: 10-50-250-500-1000 at 1000 ohms per volt.
- DC Milliampere Scale Reads: 1-10-50-250.
- Ohms Scale Reads: Low 1/2-300; High 250,000.
- Black Molded Case and Panel.
- Low Loss Selector Switch.
- Complete with Alligator Clips, Battery and Test Leads.

DEALER PRICE **\$15.00**

SEE YOUR JOBBER • WRITE FOR CATALOG



ELECTRICAL INSTRUMENTS

The Triplet Electrical Instrument Co.
271 Harmon Ave., Bluffton, Ohio

Without obligation please send me more information Model 666.

I am also interested in.....

Name

Address

City..... State